

Ethnozoological Knowledge and Family Economics on Attitudes and Behavior in Using Turtles

Dwi Setyawan¹, Syahrul Gunawan^{*2}, Ainur Rofieq³, Wahyu Prihanta⁴, Fendy Hardian Permana⁵
(Received: 7 February 2024 / Revised: 16 February 2024 / Accepted: 9 March 2024)

Abstract—The mutual interaction between humans and animals in the field of ethnozoology includes uses that can be oriented towards conservation or exploitation efforts. However, excessive abuse of sea turtles (*Chelonioidea*), especially in the direction of exploitation, has led to population decline and threatens their extinction. Observations in the Derawan Island community, Berau Regency, show a decrease in the number of turtles coming to lay their eggs due to overexploitation. To overcome this problem, it is necessary to carry out research that looks for factors that influence attitudes and behavior in using turtles, including the level of ethnozoological knowledge and family economic status. This research uses a quantitative approach with an analytical correlational design and applies Path Analysis. The results of the analysis show that the level of ethnozoological knowledge has a significant influence on attitudes, with a path coefficient of 0.298 in block 1. In block 2, the results of the analysis show that the level of ethnozoological knowledge directly influences turtle utilization behavior with a path coefficient of 0.313. In conclusion, the level of ethnozoological knowledge has a dominant role in shaping turtle utilization behavior in Derawan Island

Keywords—Derawan Island, Ethnozoology, Learning Resources, Path-analysis, Turtle

I. INTRODUCTION

Ethnozoology, as a branch of ethnobiology, focuses research on the relationship between humans and wildlife within the framework of the culture and traditions of local communities. This involves analyzing animal use, knowledge, cultural practices and impacts, including human health [1], [2]. According to [3] in their work, ethnozoology covers various aspects, including the way humans use wildlife and its relationship to tradition and its impact on the environment. Therefore, ethnozoological studies are very important to understand the complex interactions between humans and wildlife and their impact on environmental sustainability and natural resource conservation.

The concept of animal use in ethnozoological studies involves a deep understanding of interactions between humans and animals in the context of culture, traditions and local community life [1]. Research in ethnozoology looks at how humans use, exploit, and manage various types of animals to meet their needs. The use of animals in ethnozoological studies covers various aspects, such as the use of animals as a source of food and traditional medicine, craft materials, as well as in economic activities and traditional ceremonies [4]. Apart from that, it is not uncommon for endangered animals to be used by humans, both in the context of conservation and exploitation. One example of a rare animal that is used by humans is the turtle, as has been researched by [5] where turtles are often involved in myths related to magical powers and are also

targets of capture for consumption and trade for economic purposes.

Turtles (*Chelonioidea*) are one of the reptiles that can migrate long distances throughout the Indian Ocean, Pacific Ocean and Southeast Asia. According to [6], turtles migrate with the aim of mating, looking for breeding grounds and looking for food. There are six types of turtles that live in Indonesian sea waters, namely green turtles (green turtle, *Chelonia mydas*), olive ridley turtles (olive ridley, *Lepidochelys olivacea*), loggerhead turtles (*Caretta caretta*), hawksbill turtles (hawksbill, *Eretmochelys imbricata*), turtles leatherback (leatherback, *Dermochelys coriacea*), and flatback turtle (flatback, *Natator depressus*) [7]. Turtles have an important influence in maintaining the balance of the marine ecosystem. Turtles can maintain the balance of productive coral reef ecosystems and transfer important nutrients from the ocean to the coast [8].

The Indonesian government is trying to protect turtles through the implementation of PP No. 7 of 1999 concerning Preservation of Plant and Animal Types and PP No. 8 of 1999 concerning the Utilization of Wild Plant and Animal Species has protected all types of turtles in Indonesia, prohibiting trade both alive and dead [6]. However, these regulations do not have a significant impact on turtle populations. All turtle species in Indonesia are experiencing population declines that threaten their existence [7]. To overcome this problem, the government needs to take further action by implementing prevention efforts in areas where turtles often lay their eggs [9].

Dwi Setyawan Departement of Biology Education, Universitas Muhammadiyah Malang, Malang, 65144, Indonesia. E-mail: dwis@umm.ac.id

Syahrul Gunawan Departement of Biology Education, Universitas Muhammadiyah Malang, Malang, 65144, Indonesia. E-mail: sg140601@gmail.com

Ainur Rofieq Departement of Biology Education, Universitas Muhammadiyah Malang, Malang, 65144, Indonesia. E-mail: rofieq@umm.ac.id

Wahyu Prihanta Departement of Biology Education, Universitas Muhammadiyah Malang, Malang, 65144, Indonesia. E-mail: wahyuprihanta@umm.ac.id

Fendy Hardian Permana Departement of Biology Education, Universitas Muhammadiyah Malang, Malang, 65144, Indonesia. E-mail: fendy@umm.ac.id

Derawan Island Village in the Derawan Islands has characteristics that are suitable as turtle habitat, so turtles often choose to lay their eggs in this area [9], and conservation efforts have been carried out by the local community, although illegal hunting still occurs. The conservation program in this area is managed by BKSDA with community participation, but the use of turtles for economic purposes still continues. On nearby Sangalaki Island, large numbers of turtle eggs were found, contributing to 30% of the total turtle eggs in Berau Regency [10]. Factors such as lack of ethnozoological knowledge, economic pressures, societal attitudes, and behavior influence these exploitation practices.

Ethnozoological knowledge provides insight into the important role of sea turtles in marine ecosystems and the negative impacts of exploitation on them, including decreasing water quality and loss of biodiversity [11], [12]. In addition, family economic status influences individual behavior in using turtles. In conditions of economic limitations, individuals tend to seek economic benefits from turtles to meet their daily needs [13]. Individual attitudes also play an important role, with positive attitudes supporting responsible behavior and conservation, while negative attitudes can encourage irresponsible behavior [14], [15]. Factors such as knowledge, education, culture, and role models influence individual attitudes, which can change through education and awareness. Overall, good knowledge about sea turtles and conservation motivates individuals to act responsibly, while increasing awareness of sea turtles' contributions to the ecosystem and the threats they face.

The importance of adequate knowledge in preventing harmful exploitation of animals is widely recognized. Lack of knowledge can lead to behavior that is detrimental to the environment and species [16]. Therefore, formal and non-formal education plays an important role in obtaining this knowledge. Through the use of appropriate learning resources, including research results, understanding of ethnozoology and its impact on human actions related to animal exploitation can be improved [17]. The availability of relevant learning resources is an important factor in increasing public awareness and understanding of this issue, as well as supporting efforts to maintain environmental sustainability.

Ethnozoology-based research has not yet been carried out much, especially regarding the use of turtles in Derawan Island Village. Previous research was conducted by [5], which examined the relationship between turtle use, knowledge, education, economics and community attitudes. Apart from that, [18] discussed the use of Batu Cokroaches as a traditional medicine for toothache in the community of Cicenang, Majalengka. [19] noted the use of 10 types of animals, including the endangered cuscus, in traditional medicine in Sambulangan Village. [4] conducted research on the slaughter of animals in traditional events in various situations. However, more ethnozoological research is needed to understand the use of turtles in Derawan Island Village more comprehensively.

This research focuses specifically on the use of turtles in Derawan Island Village, with related variables, to provide a more detailed picture. The uniqueness of this research

lies in its emphasis on differences in community and environmental characteristics that influence behavior in using turtles, both socio-culturally and geographically [20]. One of the strengths of this research is that it uses path analysis to reveal direct and indirect relationships between variables related to turtle use [21]. It is hoped that this research can provide in-depth insight into the use of turtles in Derawan Island Village and the factors that influence it.

II. METHOD

A. Time and Location of Research

The research was carried out in September 2023. Sampling was carried out in Derawan Island Village, Berau Regency, especially in community and fishing settlements as well as conservation areas. The population used in this research is the number of heads of families (KK) in Derawan Island village who work as fishermen. The number of family heads in Derawan Island village who work as fishermen is 471 families.

B. Methods and Stages of Research

The approach to this activity uses quantitative research with an analytical correlational design. A correlational design is used to study correlational relationships between variables, while an analytical design is used to study causal relationships between variables in a path relationship model.

Probability sampling method was chosen with a simple random sampling technique where sampling is carried out randomly and each item in the population has an equal chance of being the selected sample [22]. This method was chosen because the research samples were fishermen from Derawan Island Village who were involved in the use of turtles, both conservatively and exploitatively, and had relevant knowledge and experience. Apart from that, sampling was carried out using the Taro Yamane formula explained by [23], based on this calculation, the sample used was 82.48 and rounded up to 82 respondents.

Data collection in this research was carried out using a survey method with the help of instruments. Informants in the sample were questioned through interviews. To collect data on ethnozoological knowledge of turtles, a question test was used. Data on family economic status was collected by filling out a questionnaire on ownership of valuables. Attitude tests are used to collect data on people's attitudes towards the use of turtles. Meanwhile, community behavior data was obtained through direct observation and interviews. The interview results will be converted into numerical data with the help of instruments and analyzed using Path Analysis with the SPSS for Windows version 25 program.

Data analysis involves examining cause and effect relationships through path analysis, which requires creating a path diagram that describes the relationship between variables, but before proceeding to the path analysis stage, first ensure that the data meets the prerequisite tests. This process is continued by partitioning the model into two blocks. The model of path analysis can be seen in Figure 1.

the significance value (Sig) is smaller than the predetermined threshold, namely 0.05 ($0.005 < 0.05$), it can be concluded that the alternative hypothesis (H_a) is supported while the null hypothesis (H_0) is rejected. Detailed results of each of these tests are outlined individually in Table 2.

The individual test results in block 1 as shown in Table 2 show the significance of the Ethnozoological

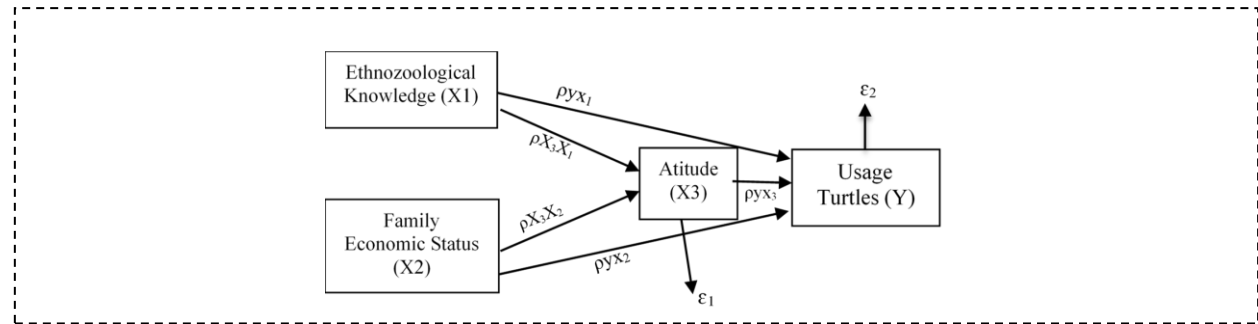

Figure 1. Path-Analysis pathway analysis scheme

III. RESULTS AND DISCUSSION

The relationship between the exogenous variable Ethnozoological Knowledge (X_1) and Family Economic Status (X_2) after testing shows that there is no relationship between these two factors.

The results of the ANOVA examination between all blocks in the scheme are depicted in Table 1. In block 1, the calculated F value was 4.640 with a probability value

Knowledge variable on Attitudes. However, the Family Economic Status variable has a value of >0.05 , which indicates that this variable does not have a direct influence on attitudes. Meanwhile in block 2, the results of individual tests regarding the relationship between the variables Ethnozoological Knowledge (X_1), Family Economic Status (X_2), and Attitudes (X_3) with Turtle Utilization (Y) as seen in Table 2 show a value of >0.05 for all variables except Ethnozoological Knowledge (X_1). This shows that the relationship between Ethnozoological

TABLE 1.
ANOVA BLOCK-1 AND BLOCK-2

Model		Sum of Squares	Df	Mean Square	F	Sig
1	Regression	626.426	2	313.213	4.640	0.012
	Residual	5333.184	79	67.509		
	Total	5959.610	91			
a. Dependent Variables: Attitude (X_3)						
b. Predictors: (Constant), Ethnozoological Knowledge (X_1), Family Economic Status (X_2)						
Model		Sum of Squares	Df	Mean Square	F	Sig
1	Regression	2192.690	3	730.897	4.611	0.005
	Residual	12362.871	78	158.498		
	Total	14555.561	81			
a. Dependent Variable: Usage Turtles (Y)						
b. Predictors: (Constant), Ethnozoological Knowledge (X_1), Family Economic Status (X_2), Attitude (X_3)						

of 0.012 which is less than 0.05. Therefore, it can be concluded that the alternative hypothesis (H_a) which states that there is a relationship between ethnozoological knowledge (X_1) and family economic status (X_2) with attitudes (X_3) is maintained at the significant threshold $\rho = 0.012 < 0.05$. while block 2 shows an F value of 4.611 with a significance level (Probability) of 0.005. Because

Knowledge (X_1) and Turtle Utilization (Y) has a significant influence.

TABLE 2.
 COEFFICIENTS BLOCK-1 AND BLOCK-2

Model		Unstandardized Coefficients		Standardized Coefficients	t	Sig
		B	Std. Error	Betas		
	(Constant)	88.170	3.910		22.550	0.000
1	Ethnozoological Knowledge (X ₁)	0.547	0.197	0.298	2.777	0.007
	Family Economic Status (X ₂)	0.004	0.004	0.094	0.880	0.381
a. Dependent Variables: Attitude (X ₃)						
Model		Unstandardized Coefficients		Standardized Coefficients	t	Sig
		B	Std. Error	Betas		
	(Constant)	67.817	16.338		4.151	0.000
1	Ethnozoological Knowledge (X ₁)	0.897	0.316	0.313	2.837	0.006
	Family Economic Status (X ₂)	0.000	0.007	0.005	0.046	0.964
	Attitude (X ₃)	0.240	0.172	0.154	1.392	0.168
a. Dependent Variables: Usage Turtles (Y)						

To test the combined effect of research variables, the summary model, especially R_{square} (R²) can be seen in Table 3. To find $\sqrt{1 - R^2}$ (the remaining variable) it is determined using the following formula:
 $\sqrt{1 - R^2} = \sqrt{1 - 0.105} = 0.895$.

that have the potential to influence turtle use, factors that have not been identified or explored in this study. Meanwhile, Block 2 shows that the correlation coefficient (R²) between the variables Ethnozoological Knowledge (X₁), Family Economic Status (X₂), and Attitude (X₃)

TABLE 3.
 MODEL SUMMARY OF BLOCK-1 AND BLOCK-2

a. Block 1 Summary									
Model	R	R Square	Adjusted Square	Std. Error of the Estimate	Change Statistics				
					R Square Change	F Change	Df1	Df2	Sig F Change
1	0.324	0.105	0.082	8.216	0.105	4.640	2	79	0.012
b. Block 2 Summary									
Model	R	R Square	Adjusted Square	Std. Error of the Estimate	Change Statistics				
					R Square Change	F Change	Df1	Df2	Sig F Change
1	0.388	0.151	0.118	12.590	0.151	4.611	3	78	0.005

The results of the calculation according to the formula show the residual value findings from Block 1 testing, which shows an R_{square} value of 0.895. These values indicate residual factors outside the scope of this study

towards Turtle Utilization is 0.151. The residual value is calculated as $\sqrt{1-0.151}$, resulting in 0.849. Therefore, it can be concluded that the relationship between Ethnozoological Knowledge, Family Economic Status,

and Attitudes towards Turtle Utilization is 0.151 or 15.1%, while the remaining 84.9% is caused by other variables not taken into account in this research, which are limitations of this research. researchers and cannot be explained in this study. These values indicate residual factors outside the scope of this study that have the potential to influence turtle use, factors that have not been identified or explored in this study. Based on the results of the block 1 and block 2 path coefficients, it can be described as a whole the empirical causal relationship between variables X_1 , X_2 , and X_3 to Y as shown in Figure 2.

The data results as shows in Figure 2 demonstrates that the variable Ethnozoological Knowledge exhibits a direct

education, as well as limited access to obtain ethnozoological knowledge. Generally, the ethnozoological knowledge received by the community comes from participation in conservation activities, although not all residents participate in these activities. The level of ethnozoological knowledge can directly influence how a person uses animals because ethnozoology includes local knowledge about animal resources, including their identification, utilization and management [5]. Lack of public knowledge regarding ethnozoology can result in less informative decision making and inaccurate views regarding the use of turtles.

Therefore, based on low knowledge of ethnozoology, society takes advantage of its lack of knowledge. A

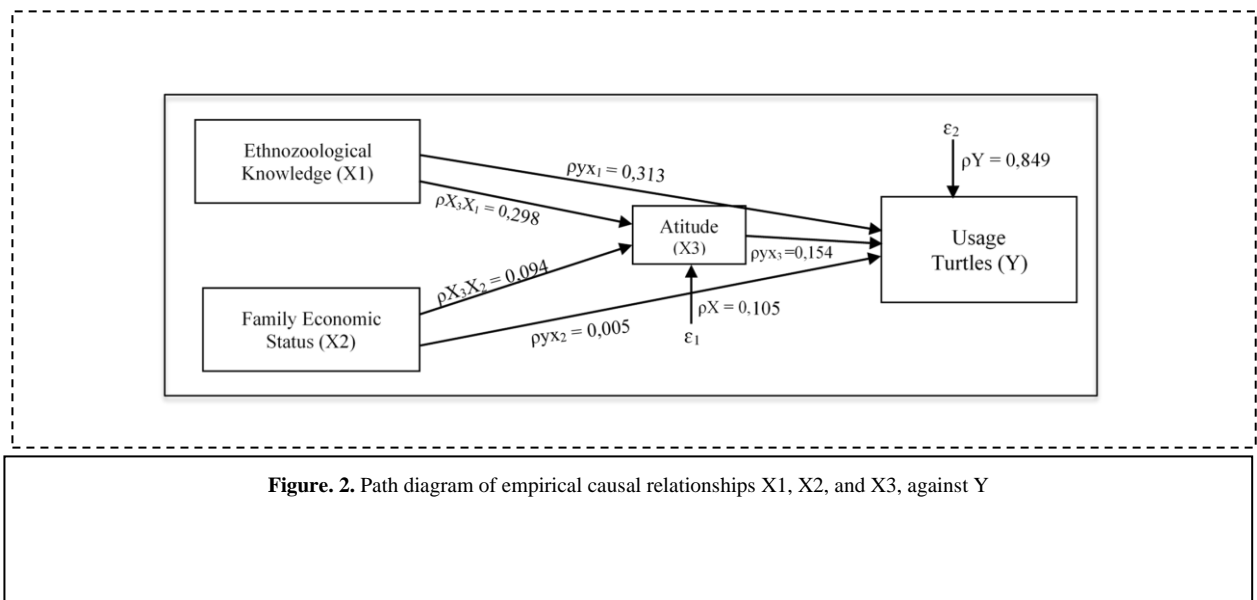

relationship with the Usage of Turtles (Y) with a coefficient of 0.313, and an indirect relationship with a coefficient of 0.359. Conversely, the variable Family Economic Status does not exhibit a significant direct relationship with the Usage of Turtles (Y), but it does have an indirect relationship through attitude with a coefficient of 0.019. As for the variable Attitude (X_3), it shows a coefficient of 0.154. However, the residual value represents the limitations of the researcher and remains unexplained within this study.

Based on the research results obtained, there is a significant direct influence between ethnozoological knowledge (X_1) on attitudes (X_3) and a significant influence on turtle utilization behavior (Y) directly. The ethnozoological knowledge variable (X_1) is the main influence on the attitude variable (X_3) in this research. Therefore, people's attitudes towards the use of turtles are influenced by the extent of a person's understanding of turtle ethnozoology. A person's attitude towards an object is influenced by the extent of their knowledge in understanding the object [5].

The test results show that there is a variable level of ethnozoological knowledge (X_1) which has a significant effect on turtle use (Y) with a coefficient value of 0.313. These results reflect the situation in Derawan Island Village where the community's ethnozoological knowledge is still limited in terms of information and

person's knowledge can influence attitudes and behavior because knowledge can influence a person's thoughts and feelings towards an object or action [24]. A person's in-depth knowledge will help him consider a problem before taking action, so that he can make wise and appropriate decisions. The need for more in-depth education regarding ethnozoology is needed in adopting attitudes and behavior as seen in block-1 and block-2 where the level of ethnozoological knowledge has the greatest and most significant influence on both attitudes and behavior in the use of turtles. If people's ethnozoological knowledge about turtles is low, then excessive and unwise use of turtles will continue to occur.

In the results of the path analysis for family economic status (X_2), there is a direct but not significant influence on attitudes (X_3) or directly on turtle utilization behavior (Y). This can be related to conditions developing in society. Communities whose livelihoods are fishermen and most conservation actors have a fairly prosperous level. According to [25], the Derawan tourist island destination is managed by a number of local entrepreneurs and has received attention from the government. This island provides a variety of complete tourist facilities, including accommodation such as resorts, inns and homestays, as well as culinary options and souvenirs. Apart from that, visitors can enjoy various water sports activities such as diving, snorkeling, banana boating, jet

skiing, sailing and fishing. Apart from that, according to [26], Derawan Island has good management in terms of human resources and the environment to support tourism. Therefore, every visitor who comes can provide additional economic income for the community through several activities, including providing tourist facilities ranging from water vehicles to tour guides, and also several communities that provide several accommodations/homestays for visitors who come. So the economic status of the community has a small influence on both attitudes (X_3) and turtle utilization

IV. CONCLUSION

The association among each research variable hinges on both direct and indirect links, particularly the influence exerted by ethnozoological knowledge and family educational status on turtle usage behavior within the community of Derawan Island Village. This implies that addressing negative turtle usage behavior could be approached through interventions targeting ethnozoological knowledge. Therefore, it is suggested that this insight be utilized as a reference by authorities in formulating effective policies and initiatives to tackle the issue of unfavorable turtle use among local fisherman communities.

ACKNOWLEDGEMENTS

We express our gratitude to the Derawan Island village government and the BKSDA organization for granting permission to access, survey, and gather the necessary data for our research in Derawan Island Village.

REFERENCES

- [1] A. Audina et al., "Etnozooologi masyarakat desa Geni Langit Kecamatan Poncol Kecamatan Poncol Kabupaten Magetan, Jawa," *Prosiding Seminar Biologi Semnas Biodiversitas*, vol. 4, no. 2, pp. 24–29, 2015, [Online]. Available: <https://www.researchgate.net/publication/335757371>
- [2] A. P. Sitingjak, M. S. Anwari, and H. Ardian, "Etnozooologi masyarakat dayak kanayatn untuk diperdagangkan di Desa Pancaroba Kecamatan Sungai Ambawang Kabupaten Kubu Raya," *Jurnal Hutan Lestari*, vol. 9, no. 3, pp. 347–353, 2021, doi: <http://dx.doi.org/10.26418/jhl.v9i3.46093>.
- [3] R. R. N. Alves and U. P. Albuquerque, *Ethnozooology: Animals in Our Lives*. Elsevier Science, 2017. [Online]. Available: <https://books.google.co.id/books?id=TjNHDgAAQBAJ>
- [4] J. E. Koa, A. T. Taboy, S. Sila, and D. F. Hanas, "Etnozooologi vertebrata masyarakat desa Be'nus kabupaten Timor Tengah Utara," *Journal Science of Biodiversity*, vol. 3, no. 2, pp. 89–94, 2022, doi: [10.46201/jsb/vol3i2pp89-94](https://doi.org/10.46201/jsb/vol3i2pp89-94).
- [5] D. Setyawan, F. Rohman, and H. Sutomo, "Kajian etnozooologi masyarakat desa Hadiwaarno kabupaten Pacitan dalam konservasi penyu sebagai bahan penyusunan booklet penyuluhan masyarakat," *JPBI (Jurnal Pendidikan Biologi Indonesia)*, vol. 1, no. 3, pp. 283–297, 2016, doi: [10.22219/jpbi.v1i3.2661](https://doi.org/10.22219/jpbi.v1i3.2661).
- [6] T. Z. A. E. Harnino, I. N. Y. Parawangsa, L. A. Sari, and S. Arsad, "Efektifitas pengelolaan konservasi penyu di turtle conservation and education center Serangan, Denpasar Bali," *Journal of Marine and Coastal Science*, vol. 10, no. 1, pp. 18–34, 2021, [Online]. Available: <https://e-journal.unair.ac.id/JMCS>
- [7] E. Firliansyah, M. D. Kusriani, and A. Sunkar, "Pemanfaatan dan efektivitas kegiatan penangkaran penyu di Bali bagi konservasi penyu," *J Trop Biodivers Biotechnol*, vol. 2, no. 1, pp. 21–27, 2017, doi: [10.22146/jtbb.25690](https://doi.org/10.22146/jtbb.25690).
- [8] M. Kurniarum, W. Prihanta, and S. Wahyuni, "Pengetahuan dan sikap masyarakat terhadap konservasi penyu dan ekowisata di desa Hadiwarno kabupaten pacitan sebagai sumber belajar biologi," *JPBI (Jurnal Pendidikan Biologi Indonesia)*, vol. 1, no. 2, 2015, doi: [10.22219/jpbi.v1i2.3321](https://doi.org/10.22219/jpbi.v1i2.3321).
- [9] D. Dharmadi and N. N. Wiadnyana, "Kondisi habitat dan kaitannya dengan jumlah penyu hijau (*Chelonia mydas*) yang bersarang di pulau Derawan, Berau-Kalimantan Timur," *Jurnal Penelitian Perikanan Indonesia*, vol. 14, no. 2, pp. 195–204, 2008.
- [10] A. Ibrahim, D. Djumanto, and N. Probosunu, "Sebaran lokasi peneluran penyu hijau (*Chelonia mydas*) di pulau Sangalaki Kepulauan Derawan Kabupaten Berau," *Jurnal Perikanan Universitas Gadjah Mada*, vol. 18, no. 2, pp. 39–46, 2016, doi: [10.22146/jfs.26214](https://doi.org/10.22146/jfs.26214).
- [11] S. R. Kaunang, I. N. Asyiah, and S. Aprilya, "Etnobotani (pemanfaatan tumbuhan secara tradisional) dalam pengobatan hewan ternak oleh masyarakat using di Kabupaten Banyuwangi," *Indonesian Journal of Biotechnology and Biodiversity*, vol. 3, no. 1, pp. 27–32, 2019, doi: <https://doi.org/10.47007/ijobb.v3i1.34>.
- [12] A. N. Saputri and I. Murtini, "Kajian etnozooologi berupa penyembelihan kambing dalam acara nyewu di dusun jahulu desa Sumberan Kecamatan Bancar Kabupaten Tuban," *Prosiding SNasPPM*, vol. 7, no. 1, pp. 402–406, 2022, [Online]. Available: <http://prosiding.unirow.ac.id/index.php/SNasPPM/article/view/1351%0Ahttp://prosiding.unirow.ac.id/index.php/SNasPPM/article/download/1351/817>
- [13] Junaidi and Zulgani, "Peranan sumberdaya ekonomi dalam pembangunan ekonomi daerah," *Jurnal Pembangunan Daerah Edisi III*, vol. 1, no. 2, pp. 27–33, 2011, [Online]. Available: <http://repository.unja.ac.id/id/eprint/239>
- [14] Y. Sadono, "Peran serta masyarakat dalam pengelolaan taman nasional Gunung Merbabu di Desa Jeruk Kecamatan Selo, Kabupaten Boyolali," *Jurnal Pembangunan Wilayah & Kota*, vol. 9, no. 1, p. 53, 2013, doi: [10.14710/pwk.v9i1.6526](https://doi.org/10.14710/pwk.v9i1.6526).
- [15] S. Syamaun, "Pengaruh budaya terhadap sikap dan perilaku keberagamaan," *Jurnal At-taujih Bimbingan Dan Konseling Islam*, vol. 2, no. 2, pp. 81–95, 2019, doi: [http://dx.doi.org/10.22373/taujih.v2i2.6490](https://doi.org/10.22373/taujih.v2i2.6490).
- [16] Y. J. Damsy, S. Supriadi, and W. Rivai, "Peran orang tua dan guru dalam mengatasi sikap dan perilaku menyimpang anak," *Pendidikan Dan Pembelajaran*, vol. 3, no. 2, 2014, [Online]. Available: [http://dx.doi.org/10.26418/jppk.v3i2.4617](https://doi.org/10.26418/jppk.v3i2.4617)
- [17] M. Umami, "Integrasi etnozooologi berbasis hukum islam sebagai upaya menumbuhkan keterampilan konservasi lingkungan," *Jurnal Ilmu Alam Indonesia*, vol. 2, no. 1, pp. 1–7, 2019, [Online]. Available: <http://www.syekhnhurjati.ac.id/jurnal/index.php/jia/article/view/>.
- [18] Atun, D. T. Komalasari, H. Noviasari, S. Nurkholifah, and M. Umami, "Kajian etnozooologi kecoa batu (*Nauphoeta cinerea*) dalam upaya konservasi hewan berkelanjutan," in *Prosiding Seminar Nasional Pendidikan Biologi, Cirebon*, 2020, pp. 49–53.
- [19] W. A. Karim, M. F. Haruna, R. S. Ndekano, and F. N. Lige, "Etnozooologi terhadap pemanfaatan hewan sebagai pengobatan tradisional di desa Sambulangan kecamatan Bulagi Utara kabupaten Banggai Kepulauan," *Bioscientist : Jurnal Ilmiah Biologi*, vol. 10, no. 1, pp. 417–425, 2022, doi: [10.33394/bioscientist.v10i1.5037](https://doi.org/10.33394/bioscientist.v10i1.5037).
- [20] A. Setyawan, "Potensi pengembangan pariwisata 'Pantai Baru' di desa Poncosari Kecamatan Srandakan Kabupaten Bantul," *Jurnal Pendidikan Geografi UNY*, vol. 1, no. 4, pp. 1–8, 2018, [Online]. Available: <https://journal.student.uny.ac.id/ojs/index.php/geo-ecucasia/article/view/3644/3314>
- [21] Zainuddin and G. Salim, "Pengenalan coastal clean-up di kawasan ekowisata Pulau Derawan, kabupaten Berau,

- Kalimantan Timur,” *Jurnal Pengabdian Masyarakat Borneo*, vol. 2, no. 2, pp. 37–43, 2018.
- [22] R. E. Kirk, “Simple Random Sample,” in *International Encyclopedia of Statistical Science*, M. Lovric, Ed., Berlin, Heidelberg: Springer Berlin Heidelberg, 2011, pp. 1328–1330. doi: 10.1007/978-3-642-04898-2_518.
- [23] R. Riduwan and E. A. Kuncoro, *Cara Menggunakan dan Memaknai Path Analysis (Analisis Jalur)*. Bandung: Alfabeta, 2007. Accessed: Feb. 03, 2024. [Online]. Available: <https://openlibrary.telkomuniversity.ac.id/pustaka/10141/cara-menggunakan-dan-memaknai-analisis-jalur-path-analysis-.html>
- [24] J. Betty, K. Jusuf, and A. T. Raharja, “Tingkat pengetahuan dan sikap mahasiswa program studi pendidikan olahraga Universitas Muhammadiyah Kalimantan Timur terhadap permainan tennis,” *Jurnal Pendidikan Jasmani Indonesia*, vol. 15, no. 2, pp. 70–79, 2019, Accessed: Feb. 03, 2024. [Online]. Available: <https://www.academia.edu/download/97437972/pdf.pdf>
- [25] Y. H. Tendy, A. Subagiyo, and G. Prayitno, “Daya dukung lingkungan hidup Pulau Derawan sebagai kawasan pariwisata dan konservasi di kabupaten Berau,” *Planning for Urban Region and Environment*, vol. 10, no. 2, pp. 75–84, 2021, Accessed: Jan. 22, 2024. [Online]. Available: <https://purejournal.ub.ac.id/index.php/pure/article/view/180>
- [26] D. L. Putri, N. Nurmawati, and R. G. Harahap, “Strategi pengembangan rencana kawasan pesisir terpadu Pulau Derawan pasca pandemi covid-19,” *Jurnal Inovtek Polbeng*, vol. 12, no. 1, pp. 40–45, 2022, Accessed: Jan. 22, 2024. [Online]. Available: <https://www.neliti.com/publications/468754/strategi-pengembangan-rencana-kawasan-pesisir-terpadu-pulau-derawan-pasca-pandem>
- [27] M. Khairati, A. B. Rakhmat, H. A. Radde, and M. unus Sudirman, “Konformitas sebagai prediktor pengambilan keputusan untuk menjadi pelaku demonstrasi pada mahasiswa di kota Makassar,” *Edupsyscouns*, vol. 4, no. 1, pp. 1–13, 2022, doi: <https://doi.org/10.33487/edupsyscouns.v4i1.3901>.
- [28] E. L. Risyawirasthi, “Konformitas mahasiswa fakultas ilmu pendidikan Universitas Negeri Surabaya setelah masa perkuliahan online,” *Character: Jurnal Penelitian Psikologi*, vol. 9, no. 5, pp. 196–205, 2022, Accessed: Nov. 23, 2023. [Online]. Available: <https://ejournal.unesa.ac.id/index.php/character/article/view/47816>
- [29] S. Tutiana, D. Sulistiana, and F. N. Isti’adah, “Analisis konformitas negatif kelompok teman sebaya pada siswa,” *FOKUS*, vol. 6, no. 3, pp. 71–81, 2023, doi: 10.22460/fokusv6i3.17687.