

## Wave Transmission Analysis on Hexagonal Shape Floating Breakwater

Sujantoko<sup>a\*</sup>, Haryo Dwito Armono<sup>a</sup>, Wisnu Wardhana<sup>a</sup>, and Dedi Kurniawan<sup>a</sup><sup>a</sup>) Department of Ocean Engineering, Institut Teknologi Sepuluh Nopember, Surabaya 60111, Indonesia

\*Corresponding Author: sujantoko@oe.its.ac.id

### ABSTRACT

Coastal areas have many benefits for activities, such as port construction, fishing activities, recreation areas, resource utilization, alternative energy-producing places, etc. However, many factors limit this use due to water wave activity, such as storm surges and the potential for tsunamis. These factors also cause abrasion and coastal erosion that can damage the coastal environment. To overcome this problem, it can be done by building a coastal protective structure, one of which is a floating breakwater. In this study, analysis of wave transmission on a hexagonal floating breakwater will be carried out to determine the effectiveness of its performance. The wave transmission test on the floating breakwater was carried out with variations of irregular waves (Jonswap spectrum) and mooring angles. The position of the wave probe is set at 100 cm and 220 cm behind the structure. The largest transmission coefficient occurs at a mooring angle of 30° in both scenario 1 and scenario 2. The smallest transmission coefficient value is at an angle of 60° in both scenarios of wave probe placement. The plotting results show that the transmission coefficient is directly proportional to the period and height of the incident wave and vice versa the transmission coefficient is inversely proportional to the steepness of the wave.

**Keywords:** floating breakwater, hexagonal, wave transmission, mooring line angle

### 1. INTRODUCTION

The main problem that often occurs in coastal areas is abrasion caused by ocean wave activity. The abrasion on this beach can be prevented by building a coastal protective structure to reduce the wave energy. One of which is a breakwater or breakwater structure, this structure can be used to reduce the energy of the incoming waves so that the energy level is lower when they hit the shoreline. floating breakwater is a suitable alternative solution to overcome these problems. In the last few decades, research on floating breakwaters has increased by taking into account its advantages which are flexible to be developed, efficient to dampen the waves, simple to construct, inexpensive, and efficient length size [1]. Floating breakwater can be placed easily on soft soil and the construction cost depends on the water depth [2]. In addition, floating breakwaters are easy to move and reassemble with different layouts [3]. Based on its

construction, soil conditions are also very influential, floating breakwater is more suitable for use in poor soil conditions because it does not put a lot of pressure on the ground below [4]. The disadvantage of using floating breakwater is that it is less effective in the event of a storm at the location of the structure because the construction is located above the water surface and this structure is not suitable to be applied to wave heights of more than 2 meters.

The shape of the floating breakwater has been widely studied before. In general, floating breakwaters have the box, pontoon, mat, and tethered shapes [5]. This new model of floating breakwater consists of two rigid cylinders and between the two halves of a hollow cage in which there are spheres [6]. Meanwhile, experiments were carried out with a floating breakwater model in the form of a rectangular block that has two hulls or catamarans have also been investigated [7]. From these previous studies, an analysis was carried out and there were several advantages and disadvantages found for each form. The most commonly used type is a floating breakwater with a pontoon type that is connected and moored to the seabed using cables or chains. From this research, it can be seen the effectiveness of the hexagonal shape floating breakwater as presented in Figure 1. in reducing the load caused by ocean waves when they hit and pass through the structure.

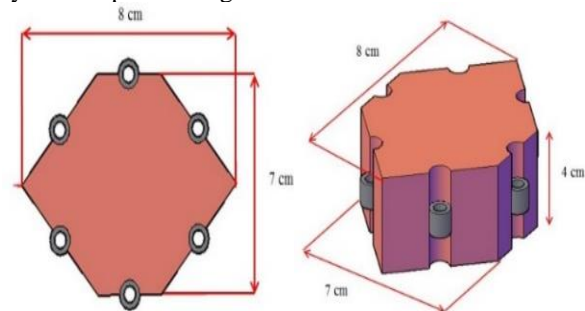

Figure 1. Design of hexagonal type floating breakwater

### 2. BASIC THEORY

#### 2.1 Irregular Wave Theory

In general, waves in the sea are very complex and difficult to formulate mathematically, because of their non-linear

nature and random shape. The series of ocean waves have different heights and periods [8] and have the following characteristics:

- a. The wave surface is irregular, it changes from time to time and varies from place to place, depending on the wind speed.
- b. Wave surface is an irregular surface.
- c. From interval to interval, the irregular pattern or waveform never repeats itself, as shown in Figure 2 below.

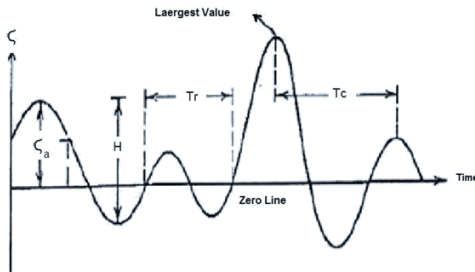

Figure 2. The definition of irregular wave [8]

Where  $\zeta$ =Wave elevation (m),  $\zeta_a$ = apparent wave amplitude (m),  $H$ = apparent wave height (m),  $T_r$ = apparent zero-crossing period, and  $T_c$ = apparent period.

Random wave measurements can be performed using zero up-crossing and zero down-crossing methods. In the zero up-crossing methods, the first thing that needs to be done is to determine the zero point, where this zero point is the average water level elevation at the time of recording. then the point of intersection between the rising curve and the zero lines is set as the start of the wave. The distance between two points is the period of the first wave ( $T_1$ ). While the vertical distance between the highest and lowest points between the two points is the height of the first wave ( $H_1$ ). Then, the steps are repeated to get a second wave, a third wave, and so on. The zero down-crossing methods have the same procedure, but what needs to be considered is the intersection of the descending curve and the zero line [9].

## 2.2. Wave Transmission

The response of the coastline to the presence of a breakwater is controlled by at least 14 variables [10], eight of which are very important variables, namely:

- a. Distance from beach
- b. Structure length
- c. Basic characteristics of the beach
- d. Wave height
- e. Wave period
- f. The angular orientation of the structure
- g. Dominant wave direction

The analysis of the wave transmission coefficient on the breakwater is determined by taking into account the non-dimensional variables. The transmission coefficient ( $K_t$ ) is

the ratio of the transmission wave height ( $H_t$ ) and the incident wave height ( $H_i$ ).

$$K_t = \frac{H_t}{H_i} \quad (1)$$

In general, based on previous research, it can be seen that the transmission coefficient is determined by the relative height of the breakwater and the steepness of the wave. Structures with steeper sides can pass larger waves than those with gentler sides, whether at sinking crests or not. Physically, this difference can be explained by the basic friction effect. The energy of a wave traveling along a slope is dissipated by friction with the surface. The sloping side has a greater length than the vertical side so that the dissipated wave energy will be more which causes the wave transmission to be smaller.

## 2.3. Physical Modeling

Physical modeling is an experiment carried out by making the same model form as the prototype with a predetermined scale. The advantages of physical modeling are that the model can integrate almost all real problems without simplifying assumptions, provides accurate data, but usually costs a lot, and contains natural variables that can cause difficulties in interpreting the data.

When experimenting in the laboratory, the model can be arranged and controlled according to the desired layout. The transformation of the prototype to this model must meet the appropriate laboratory dimensions and suitable scale considerations. The model created must be able to represent the original behavior even though it is only an approach. The thing that must be considered is the similarity of the dominant parameters between the model and the prototype so that the behavior of the model can be reinterpreted into the prototype.

This physical model study is expected to address the problem of prototyping to a model that can be created and controlled in the laboratory. Models can be used for:

- a. Predict what will happen after the structure is built.
- b. gain a high degree of confidence in the success of the structural design.
- c. Visualize and predict the appearance of buildings and their impact on the environment.

## 2.4. Hexagonal Shape Review

A hexagonal shape is a shape that is close to the shape of a circle and has a low ratio of circumference. This shape is also almost like the shape of the hull, which can provide buoyancy to prevent the ship from sinking. With this hexagonal shape, the capacity of the air voids will be much larger than the triangular or rectangular shape, so that large air cavities can provide much greater buoyancy as well. Hexagons also have a lower perimeter than rectangles that have the same area. What's interesting about this hexagonal shape is that it has far more variations in the arrangement of shapes compared to other floating breakwater shapes, such as pontoon or square shapes.

### 3. RESEARCH METHOD

#### 3.1. Problem Assessment

Based on the information and data that has been obtained, it is known that there are still many research results on floating breakwaters that give less than optimal wave transmission results. The problem studied in this research is how to get optimal wave transmission results, to improve the protection of coastal areas against the threat of abrasion.

#### 3.2. Experimental Model Design

In this study, we will use a type of physical model made of plastic or other materials. The experimental model can be made by using 3D printing to form a hexagonal model as shown in Figure 3 with a scale of 1: 10 to the prototype (Table 1)

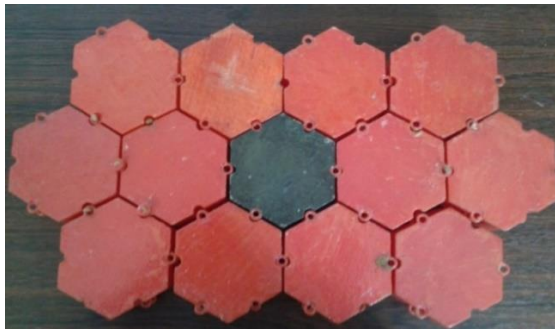

Figure 3. Hexagonal shape floating breakwater model

Table 1. Model dimension a hexagonal floating breakwater

Dimension	Model (cm)	Prototype (cm)
Length	8	80
Width	7	70
Height	4	40

#### 3.3. Test Design Model

In the physical test of the hexagonal floating breakwater, the water level is fixed at 80 cm, with variations in height ( $H=3-5$  cm), wave period ( $T = 1.1 - 1.5$  seconds), and mooring angle ( $30 - 75^\circ$ ). Tests were carried out with irregular waves and the Jonswap spectrum. Scenarios for testing the slope of the mooring angle and the placement of the wave probe can be seen in figures 4 and 5.

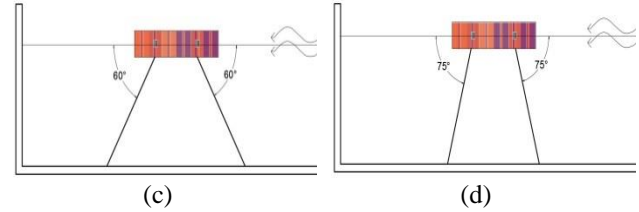
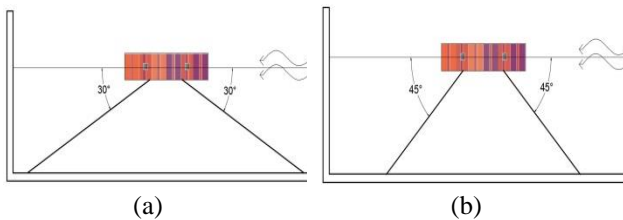

Figure 4. Variations of the mooring angle

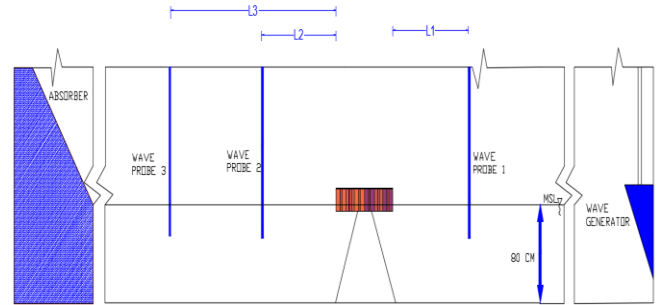

Figure 5. Wave probe placement scenario, (a) scenario 1 ( $L2=100$  cm), (b) scenario 2 ( $L3=220$  cm)

#### 3.4. Wave Probe Calibration

The wave probe functions as a wave height measuring device. If this instrument is immersed in water, the electrode will measure the conductivity of the volume of water. Since the wave probe function records wave fluctuations in the front and back of the model, it will greatly determine the results of this test, so calibration must be carried out.

The wave probe calibration process is carried out by recording the position of the zero points and the wave probe will record the calibration by raising and lowering the wave probe to the minimum and maximum points (Table 2). After the calibration process is complete, the wave probe must be returned to its original position or immersed to half the height of the wave probe. This calibration was carried out to determine the relationship between changes in electrodes immersed in water and changes in voltage recorded on the recorder.

Table 2. The results of the wave probe calibration

The Value of Capacitance (mV)	Probe 1	Probe 2	Probe 3
Minimum	1851	1861	1842
Maximum	3565	3573	3542

### 4. RESULTS AND DISCUSSION

#### 4.1. Dimensional Analysis

Dimensional analysis is carried out to make it easier to analyze the experimental data and then it can be used for the desired design. Based on the dimensional analysis, dimensionless variables will be obtained which will be the reference in the presentation of the experimental results, thus facilitating data processing. The parameters that affect the transmission coefficient can be written as follows:

$$K_t = f(H_i, H_t, T_i, g) \quad (2)$$

Where:  $H_i$  wave height (m),  $H_t$  transmission wave height (m),  $T_i$  period wave (seconds), and  $g$  acceleration of gravity ( $m/s^2$ ).

Based on dimensional analysis with the Buckingham Pi theorem, the dimensionless parameter is obtained as:

$$K_t = \left[ \frac{H_t}{H_i} \right] = f \left( \frac{H_i}{gT^2} \right) \quad (3)$$

#### 4.2. Experimental Result Calculation Analysis

To determine the relationship between the value of the transmission coefficient with other parameters, a method analytical graph is used which states the relationship between the value of the transmission coefficient and certain parameters. Based on these data, it can be seen that the value of the incoming and transmitted wave height is known, so that the value of  $K_t$  can be determined from the comparison between the transmission wave and the incident wave.

##### 4.2.1 Impact of the incoming wave period on $K_t$

Figures 6 and 7 show a graph of the relationship between the  $T_p$  and  $K_t$  in scenarios 1 and 2 of the placement of the wave probe. The graph shows that the value of  $K_t$  is directly proportional to the wave period. The greater the wave period, the greater the value of  $K_t$ . So, floating breakwater will be able to reduce waves effectively if the period of the arrival of waves is small. This condition occurs in scenarios 1 and 2, at a mooring angle of  $60^\circ$  it has the smallest  $K_t$  value compared to other mooring angles.

##### 4.2.2 Impact of the incoming wave height on $K_t$

One of the effectiveness of floating breakwater in damping waves is determined by  $K_t$ . Figures 8 and 9 show that the value of  $K_t$  is directly proportional to the height wave. This means that the higher the incoming wave hitting the structure, the greater the value of  $K_t$ . At a mooring angle of  $60^\circ$ , it gives the smallest coefficient value of the two scenarios of placing the wave probe.

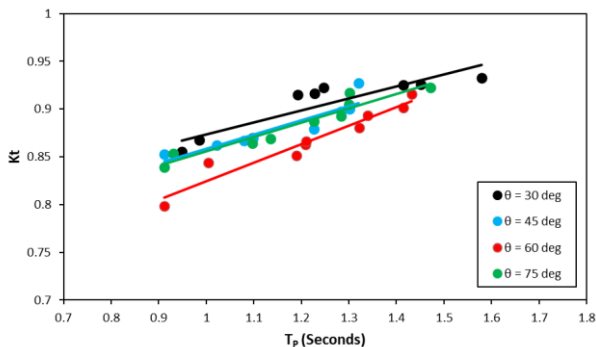

Figure 6. The relationship between  $T_p$  and  $K_t$  in scenario 1

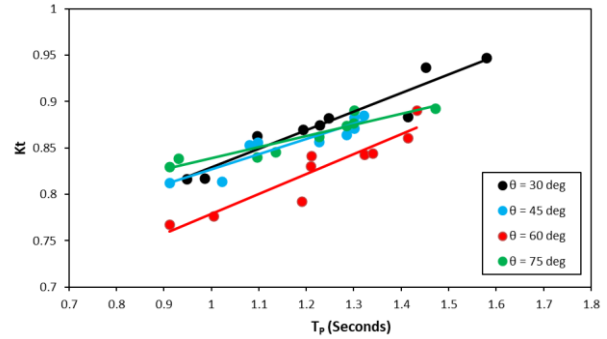

Figure 7. The relationship between  $T_p$  and  $K_t$  in scenario 2

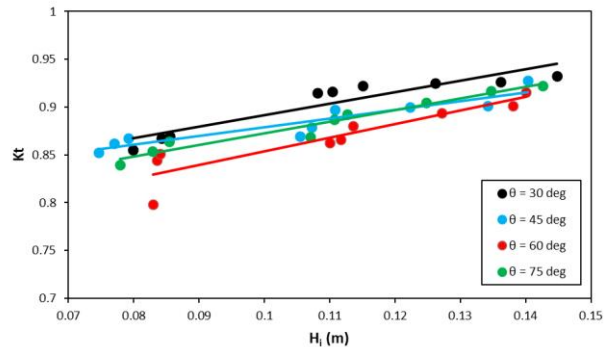

Figure 8. The relationship between  $H_i$  and  $K_t$  in scenario 1

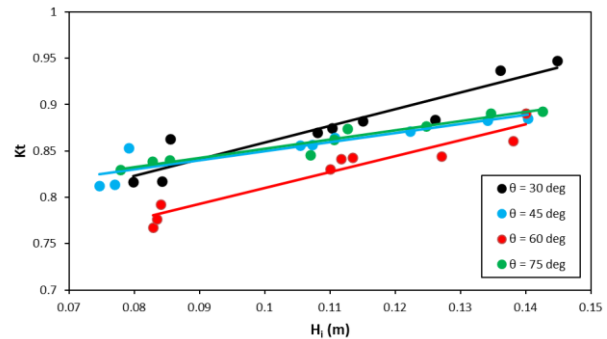

Figure 9. The relationship between  $H_i$  and  $K_t$  in scenario 2

##### 4.2.3 Impact of wave steepness on $K_t$

The effect of wave steepness on the transmission coefficient of each model can be determined using the parameters of the significant incident wave height and the average peak wave period as shown in Figures 10 and 11.

Based on Figures 10 and 11, it can be seen that the distribution of data for the four variations of mooring angles to wave steepness and transmission coefficient. The value of the transmission coefficient for the four variations of the mooring angle above is inversely proportional to the steepness of the wave. In other words, the value of the transmission coefficient increases with the decrease in the steepness of the wave. Whereas the value of the transmission coefficient decreases with the increase in the value of the steepness of the wave. The lowest wave

transmission coefficient is found at higher wave steepness values. This condition shows that waves with small wave slopes tend to be transmitted and form large transmission waves.

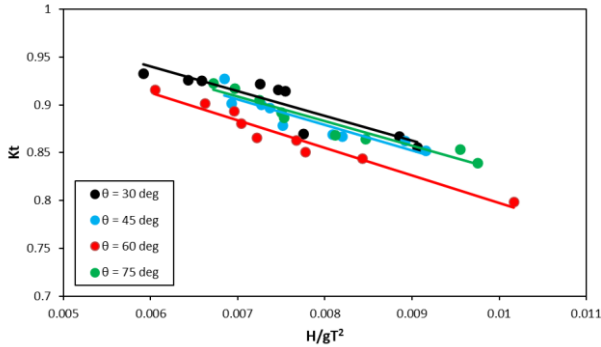

Figure 10. Relationship between wave steepness to  $K_t$  in scenario 1

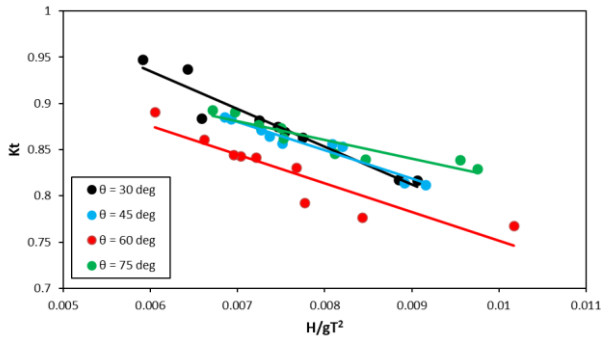

Figure 11. Relationship between wave steepness with  $K_t$  in scenario 2

#### 4.2.4 Comparison of the results of the transmission coefficient in scenarios 1 and 2

Figure 12 shows a comparison of the results of the transmission coefficient ( $K_t$ ) based on the placement of the wave probe. In scenario 1, the wave probe is placed 100 cm behind the structure (wave probe 2). While in scenario 2, the wave probe is positioned at 220 cm behind the structure (wave probe 3). This variation is done to find out how effective the structure is in damping waves at a certain distance.

Based on these calculations, it can be seen that the distance of the wave probe to the structure greatly affects the value of the transmission coefficient. In scenario 1 the average value of  $K_t$  is 0.85-0.93, while in scenario 2 the average value of  $K_t$  is 0.77-0.89. Scenario 2 with the wave probe placed at 220 cm behind the structure can reduce the average  $K_t$  by 3.85% against the wave probe at a distance of 100 cm (scenario 1).

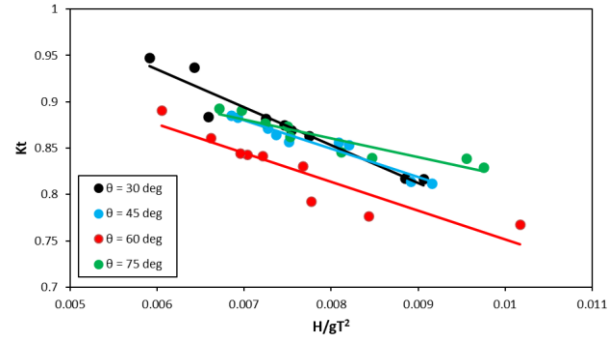

Figure 11. Relationship between wave steepness to  $K_t$  in scenario 2

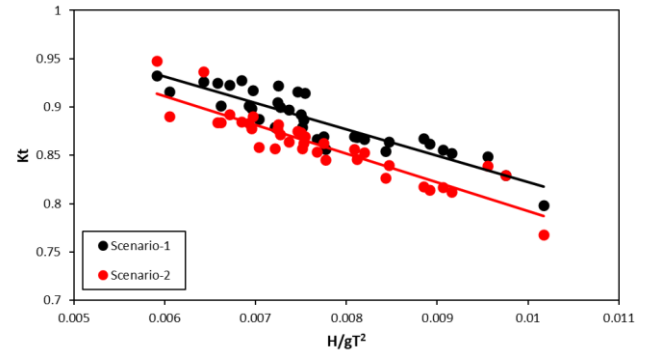

Figure 12. The relationship between  $K_t$  and wave steepness in scenarios 1 and 2

## 5. CONCLUSIONS

### 5.1. Conclusions

The hexagonal floating breakwater model has been designed and researched through experiments whose results can be concluded as follows:

- The transmission coefficient is directly proportional to the wave height and period, whereas the steepness of the wave is inversely proportional to the transmission coefficient.
- The average value of  $K_t$  in scenario 1 is 0.85-0.93 and  $K_t$  in scenario 2 is 0.77-0.89.
- Scenario 2 with the wave probe placed at a distance of 220 cm behind the structure can reduce  $K_t$  on average by 3.85% compared to the wave probe at a distance of 110 cm behind the structure (scenario 1).
- Overall angle of the mooring line  $60^\circ$  gives the smallest  $K_t$  value for both scenarios 1 and 2.

### 5.2. Suggestion

Further research can be done by modifying the model arrangement and the variation of wave input data and water level on the floating breakwater structure and comparing this research with numerical models so that the overall analysis can be done at a lower cost.

## REFERENCES

1. Tazaki and Ishida: *Floating Breakwater*", *United States Patent, Tokyo Japan*. 1975
2. Hyoung Cho, Il.: Transmission coefficients of a floating rectangular breakwater with porous side plates, *International Journal of Naval Architecture and Ocean Engineering* 8, 53-56, 2015
3. Hales, Z.L.: *Floating Breakwater; State-of-the-art Literature Review*, Technical Report No. 81-1. US Army Engineer Waterways Experiment Station, Vicksburg, Mississippi, USA, 1981.
4. Fousert, M.W.: Floating Breakwater Theoretical Study of Dynamic Wave Attenuating System, *Final Report of The Master Thesis*, Delft University of Technology, Faculty of Civil Engineering and Geoscience. 2006
5. McCartney, Bruce, L.: Floating Breakwater Design, this paper is part of the *journal of the waterway, Port, Coastal and Ocean Engineering*", Vol. 111, No. 2, March 1985
6. Chun, Y.J., Chen, Xiang, Cui, Ji, Yuan, Zhi-Ming, Incecik, Atilla: Experimental study of a new type of floating breakwater, *Ocean Engineering* 105, 295-303, 2015
7. Peña, E., Ferreras, J., Sanchez-Tembleque, F.: Experimental study on wave transmission coefficient, mooring lines, and module connector forces with different designs of floating breakwaters, *Ocean Engineering* 38, 1150-1160. 2011
8. Bhattacharyya.: *Dynamics of Marine Vehicles*, a Wiley Interscience Publication, John Wiley & Sons, New York. 1972
9. Triatmodjo, Bambang: *Teknik Pantai*, Yogyakarta: Beta Offset. 1999
10. Hanson, Hans, and Nicholas C. Kraus.: Shoreline Response to a Single Transmissive Detached Breakwater: 22<sup>nd</sup> *International Conference on Coastal Engineering, Delft, The Netherlands*. 1990