

Design and Analysis of ECVT on Electric Powered Vehicles for Determining the Speed Ratio

Himmawan Sabda Maulana*, I Nyoman Sutantra

Department of Mechanical Engineering, Institut Teknologi Sepuluh Nopember, Surabaya 60111, Indonesia

Received: 12 March 2021, Revised: 2 August 2021, Accepted: 13 August 2021

Abstract

Electronics Continuous Variable Transmission (ECVT) is a smart transmission that has unlimited gear ratios. By analyzing vehicle conditions, ECVT can choose the most efficient gear ratio. ECVT mode requires a Planetary Gear Set (PGS) as a power splitter. This research will use PGS and double electric motor to combine the ECVT mode with electric vehicles to determine the desired speed ratio. The PGS was designed by an analytical model and simulated using CAD software. The simulation will provide several input variations to get the right speed ratio, such as speed variations and rotational direction. The analytical model obtained a PGS ratio of 1:6 with 19 sun gear teeth, 95 ring gear teeth, 38 planet gear teeth, and a motor power of 47 kW. Simulation results will be applied to build the prototype that will be made with a 3D printer. This study shows that ECVT can be a transmission system for electric vehicles with 2 to 5 levels of transmission, and using double electric motors with small power can replace an electric motor with large power. To obtain maximum efficiency, a good control strategy is needed. The control strategy will be discussed in further research.

Keywords: ECVT, PGS, speed ratio, design, simulation, prototype

1. Introduction

Electric vehicles (EV) have become increasingly attractive in recent years as the most feasible solution to help protect the environment and achieve high energy efficiency in the mode of transportation [1]. One of the analysis on the power and transmission performance of the electric vehicle was performed in [2]. Most electric vehicles use two forms of the propulsion system, namely an independent drive system (in-wheel drive) and a single propulsion system [3] and [4]. The independent drive system can simplify the structure of the transmission system. Still, this system has more precise requirements regarding the torque of the electric motor, the life of the electric motor, and a high degree of control difficulty and poor safety [5]. On the other hand, a single propulsion system has been used in most modern electric vehicles, but it is still considered inefficient. It cannot be avoided that a large amount of heat is generated by a single motor when climbing steep slopes due to the low motor energy efficiency at low rotational speeds [6]. It is therefore desirable for an electric vehicle to have a multi-speed transmission, [7–10]. In the study of the gearbox system, the results showed a reduction in energy consumption of about 6% and a significant reduction in motor size [11, 12].

Planetary Gear Set (PGS) is usually used as a hybrid vehicle transmission and electric vehicle because PGS allows multiple input/output with rotational speed, which is related to one another. PGS consists of three compo-

nents (planet gear, carrier, sun gear, and ring gear), and each component can be used as input, output, or fixed. Compared to conventional gear arrangements, PGS has many advantages: more options to produce ratios, lighter weight, more practical components, and higher efficiency. Planetary Gear Set (PGS) is a power splitting device for Electrically Continuous Variable Transmission (ECVT) in hybrid vehicles, for example, the Toyota Prius and Ford Escape [13].

In the Electrically Continuous Variable Transmission (ECVT), two permanent-magnet motors (MG1 and MG2) are used. MG1 is used as the main drive motor and acts as a generator during braking. MG2 is a second electric motor used in initial modes such as an engine start. When the engine is running, it becomes a generator to provide additional power to meet vehicle power needs [14]. Using two sets of PGS provides more transmission control flexibility and improves vehicle performance [15]. PGS is often used to develop new transmissions. This approach uses the relative rotational speed of PGS [16].

This study focused on designing and analyzing the Electrically Continuous Variable Transmission (ECVT) mechanism using Planetary Gear Sets (PGS) on electric vehicles. This study aims to analyze the effectiveness of using the Electrically Continuous Variable Transmission (ECVT) to determine the speed ratio and torque in electric vehicles.

*Corresponding author. Email: sabda.17021@mhs.its.ac.id

2. Theoretical Method

A moving vehicle must have a thrust force greater than all the resistant forces that occur in the vehicle. The thrust is divided into F_f (thrust on the front wheels) and F_r (thrust on the rear wheels). The moving vehicle will receive resistance force, including drag force, rolling resistance, and resistance due to climbing.

Drag force on the vehicle when moving at a certain speed is dependent on the shape of the vehicle's body. The more aerodynamic, the smaller the aerodynamic drag will occur. Drag force is expressed in Equation 1.

$$R_a = \frac{1}{2} \cdot \rho_{air} \cdot C_d \cdot A_f \cdot V_a^2 \quad (1)$$

with,

$$\begin{aligned} R_a &= \text{aerodynamic resistance (N)} \\ \rho_{air} &= \text{density of air (kg/m}^3\text{)} \\ A_f &= \text{frontal area (m}^2\text{)} \\ C_d &= \text{inhibition coefficient} \\ V_a &= \text{vehicle speed (m/s)} \end{aligned}$$

While rolling resistance is force arising from the friction on the tires that rotate by the road. Several factors affect rolling resistance, including tire construction, road surface conditions, the tire's diameter, and the traction force itself. The amount of force is determined by Equation 2.

$$R_r = f_r \cdot W \quad (2)$$

with,

$$\begin{aligned} R_r &= \text{rolling resistance (N)} \\ f_r &= \text{rolling resistance coefficient} \\ W &= \text{vehicle weight (N)} \end{aligned}$$

The formula for rolling resistance coefficient (f_r) for a vehicle can be determined based on the f_o and f_s coefficients that depend on tire pressure as Equation 3.

$$f_r = f_o + f_s \cdot \left(\frac{V}{100} \right)^{2.5} \quad (3)$$

The climbing resistance force occurs because of the upward slope on the road. With the climbing resistance force, the vehicle load will increase due to the earth's gravitational force. The amount of resistance due to the slope can be calculated using Equation 4.

$$R_g = W \sin\theta \quad (4)$$

$$F_r = R_a + R_r + R_g \quad (5)$$

with,

$$\begin{aligned} R_g &= \text{climbing resistance (N)} \\ F_r &= \text{total resistance (N)} \\ \theta &= \text{angle of upward} \end{aligned}$$

After the total drag force on the vehicle are obtained based on the Equation 5 above, then determine the first and final transmission ratio with progression geometry as shown in Equation 6 and Equation 7.

$$i_1 = \frac{(W \sin\theta_{max} + f_r \cdot W + R_a) \cdot r}{T_m \cdot I_d \cdot \eta_t} \quad (6)$$

$$i_m = \frac{(f_r \cdot W + \frac{1}{2} \cdot \rho_{air} \cdot C_d \cdot A_f \cdot V_a) \cdot r}{T_m \cdot I_d \cdot \eta_t} \quad (7)$$

with,

$$\begin{aligned} T_m &= \text{motor torque} \\ \eta_t &= \text{transmission efficiency} \\ I_d &= \text{differential gear comparison} \\ r &= \text{wheel radius (m)} \end{aligned}$$

Where i_1 is the first ratio transmission, and i_m is the final ratio transmission. After determining the first and final transmission ratios, the gear ratio between the first and final transmission rates is calculated using geometric progression. This method is generally used as an initial iteration step. The engines' lowest (n_{e1}) and highest (n_{e2}) operating speed limits must be set in advance. This analysis is based on the torque characteristics of the electric motor using Equation 8 and Equation 9.

$$\frac{i_2}{i_1} = \frac{i_3}{i_2} = \frac{i_4}{i_3} = \frac{n_{e1}}{n_{e2}} = Kg \quad (8)$$

$$Kg = \left(\frac{i_m}{i_1} \right)^{\frac{1}{n-1}} \quad (9)$$

To determine the traction factor, the base speed for each transmission level (V_{bn}) must be found, and the maximum speed (V_{nmax}) of the vehicle with the n-transmission rate can be calculated by using Equation 10 and Equation 11, respectively.

$$V_{bn} = \frac{\phi \cdot r \cdot N_b}{30 \cdot I_{tn} \cdot I_g} \quad (10)$$

$$V_{nmax} = \frac{\pi \cdot r \cdot N_{nmax}}{30 \cdot I_{tn} \cdot I_g} \quad (11)$$

with,

$$\begin{aligned} I_d &= \text{differential gear comparison} \\ r &= \text{wheel radius (m)} \\ N_b &= \text{basic rotation of the motor} \\ N_{nmax} &= \text{the maximum speed of the motor} \\ I_{tn} &= \text{transmission ratio to "n"} \end{aligned}$$

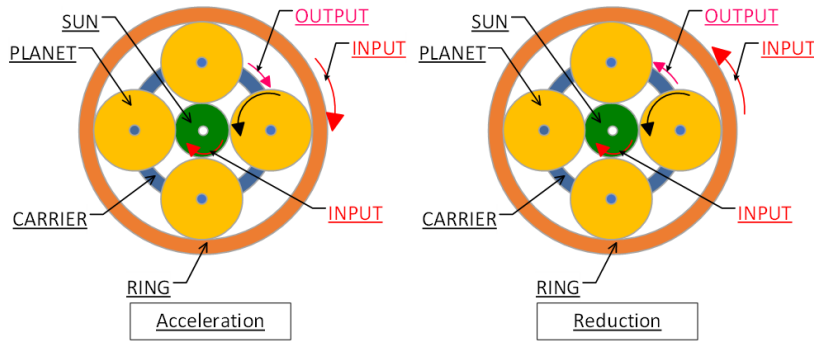

Figure 1. Variable gear ratio

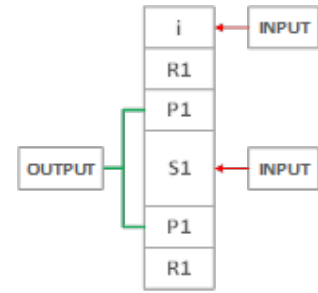

Figure 2. Modified configuration design

Thus making the formula to find the maximum and minimum traction force that can be generated at the n-transmission rate. As shown in Equation 12 and Equation 13, respectively.

$$F_{tmax} = \frac{I_{tn} \cdot I_g \cdot T_{m \max} \eta_t}{r} \quad (12)$$

$$F_{tmin} = \frac{I_{tn} \cdot I_g \cdot T_{m \min} \eta_t}{r} \quad (13)$$

The force that occurs on the vehicle can be seen from the equation described above. The Planetary Gear Set (PGS) will be designed as a power splitter from the data obtained. The PGS uses two motors as a driving force to function as a variable ratio, as shown in Figure 1. Equation 14 to Equation 16 below are to calculate carrier body rotation and torque, respectively.

$$\omega_C = \frac{N_S}{N_S + N_R} \cdot \omega_S + \frac{N_S}{N_S + N_R} \cdot \omega_R \quad (14)$$

$$T_C = \frac{N_S}{N_S + N_R} \cdot T_S + \frac{N_S}{N_S + N_R} \cdot T_R \quad (15)$$

$$T_C = (i_{S \rightarrow C} \cdot T_S) + (i_{R \rightarrow C} \cdot T_R) \quad (16)$$

In this study, the PGS variable-ratio will be modified by adding a fixed gear ratio (i) to the input of ring gear to increase the torque at the input of ring gear, as

shown in Figure 2. Therefore, k is added to the equation of variable-ratio, where (k) is the characteristic parameter of the planetary gear (ring/sun), as shown in Equation 17.

$$(1 + k)\omega_C = \omega_S + \frac{k}{i} \cdot \omega_R \quad (17)$$

with,

- ω_C = carrier body rotation
- ω_S = sun gear body rotation.
- ω_R = ring gear body rotation.
- N_S = number of sun gear teeth.
- N_R = number of ring gear teeth.
- N_P = number of planetary gear teeth.
- T_C = carrier body torque.
- T_S = sun gear body torque.
- T_R = the torque that enters the ring gear.

3. Simulation Method

The calculation results in the traction characteristics of the vehicle and the number of teeth on the PGS so that the configuration concept can be simulated. The first configuration is to determine the location of input and output with a single PGS. The configuration used in this study uses two inputs on the sun gear and ring gear and one output on the carrier gear. This configuration has the largest reduction ratio. The design configuration can be seen in Figure 3.

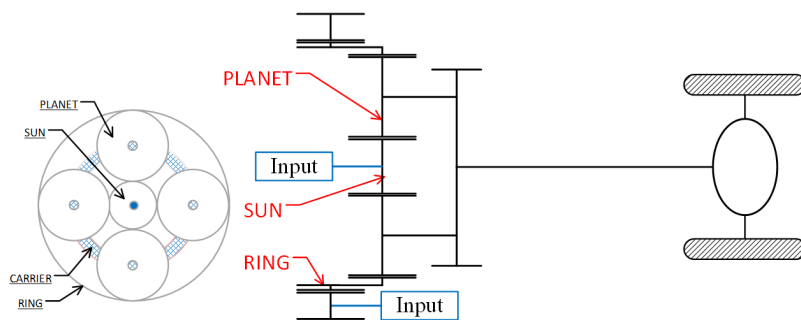

Figure 3. Configuration with Output on the Carrier

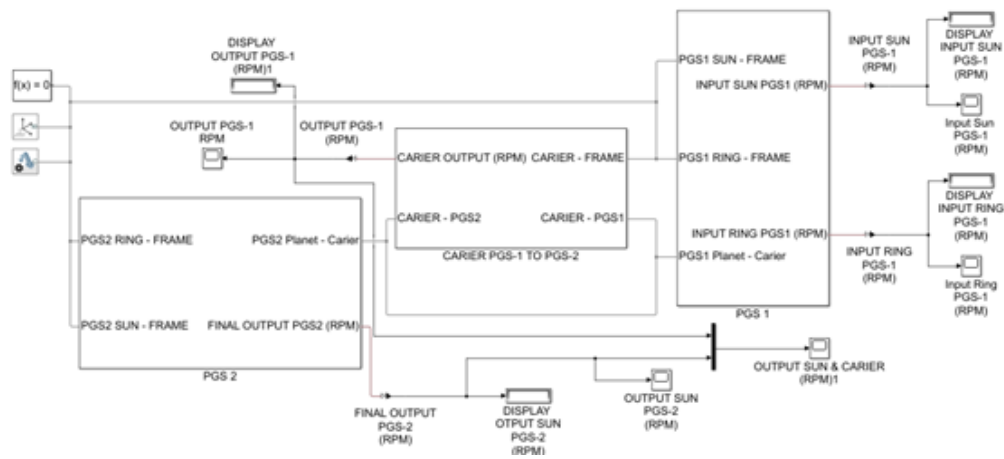

Figure 4. Simulation of ECVT-PG Speed Ratio

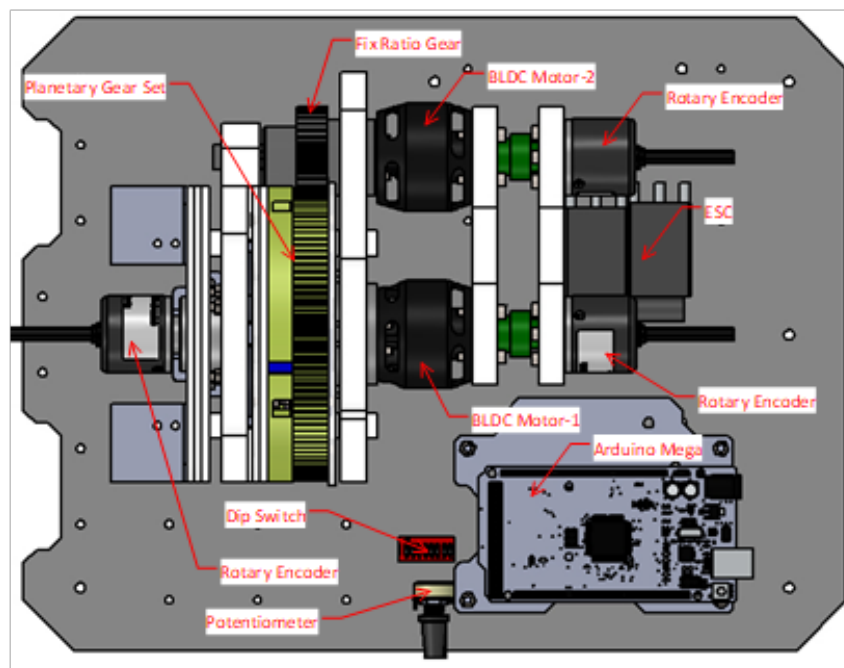

Figure 5. Prototype design

Furthermore, the direction of input and output rotation is designed with simulation in CAD software. In this simulation, mechanical simplification was used to speed up the simulation. The simplified 3D model can be seen in Figure 4. Simulation using numerical software used the *simmechanics* approach to determine the speed ratio produced by design. The *simmechanics* simulation model can be seen in Figure 4.

4. Experimental Method

The Planetary Gear Set (PGS) was made using 3D Printing. This design used a spur gear type and uses two BLDC motors, the BLDC-1 as the main driver in this system and the BLDC-2 as the auxiliary drive when the transmis-

sion is used for acceleration. BLDC-1 is connected to Sun Gear, while BLDC-2 is connected to Ring Gear. Figure 5 shows the Planetary Gear Set (PGS) design, which will be modeled and simulated in this study. From this prototype, several modes of transmission will be carried out, such as changes in the rotational direction and speed of the two motors so that from this experiment, several levels of speed and torque ratios will be obtained. The ECVT prototype simulation will use the Arduino Mega microcontroller with the addition of a Rotary Encoder sensor. Figure 5 shows the addition of a Rotary Encoder sensor to determine the input and output rotational speed. The data obtained from this experiment is used to validate the simulation results in CAD software and numerical software.

In this experiment, the writer made motor-1 as the main motor and motor-2 as the auxiliary motor. The main motor will rotate in the most efficient condition, while the motor-2 is used to control the required speed ratio. The test uses a potentiometer as a substitute for the gas pedal and a switch bar as a substitute for the specified speed level.

5. Results and Discussion

The vehicle used in this research was a Fiat sedan with the vehicle specifications shown in Table 1. For the vehicle thrust (F_t) needed, the drag force on the vehicle is analyzed. The drag force includes aerodynamic drag, rolling resistance, and climbing resistance.

After knowing the drag force, we can determine the vehicle thrust and transmission ratio required based on the power source used. Vehicle traction is designed for all resistance on the vehicle can be traversed properly. For this reason, the first step taken was to calculate air resistance (aerodynamics) with Equation 1. The results can be seen in Figure 6. In this calculation, aerodynamic resistance was minimal because the aerodynamic drag will increase with increasing speed. Usually, the vehicle's aerodynamic drag will affect the vehicle if the speed has

passed 100 km/h. If the top speed of the vehicle is below 100 km/h, the resistance will certainly remain small.

Another resistance in vehicles is the rolling resistance that occurs on vehicle tires. To calculate the value of this resistance, Equation 2 is needed, but to solve this problem, the value of f_r must be determined with Equation 3. Road conditions and tire pressure determine the value of f_r . Figure 7 shows the results of the calculation of the rolling resistance of a vehicle when driving at a certain speed. Rolling resistance was obtained from the independent variable data input of the vehicle from different rolling resistance coefficients at each speed level. Based on the graph, it can be seen that the greater speed of the vehicle, the greater rolling resistance.

When the car goes uphill, drag force is the accumulation of total resistance when driving on an upward slope with a certain gradeability value. Gradeability calculations were carried out at 0-60% slope. The value of the climbing resistance is directly proportional to the sine of the slope. The climbing resistance is the product of the vehicle weight and the sine of the upward slope the vehicle is traveling through (Equation 3). Figure 8 shows the calculation results of the car's uphill resistance on each gradient.

Table 1. Vehicle specification

Unit	Value	Notation
m	1355	kg
A	2.4	m^2
C_d	0.311	
ρ	1.205	kg/m^3
f_r	0.005	
g	9.81	m/s^2
r	0.292	m
π	3.1415	

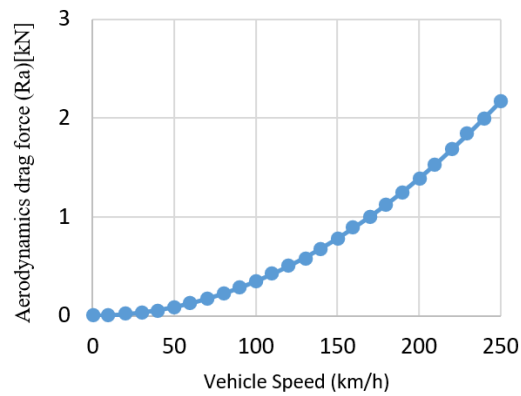

Figure 6. Aerodynamic resistance 0-250 km/h

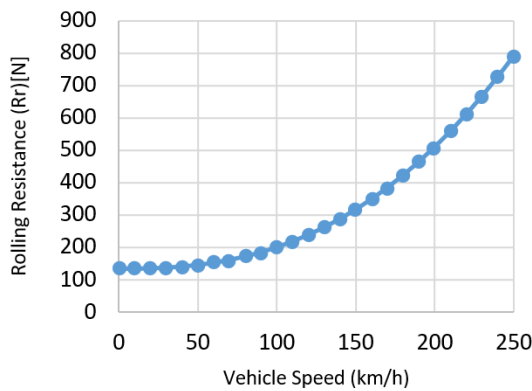

Figure 7. Rolling resistance 0-250 km/h

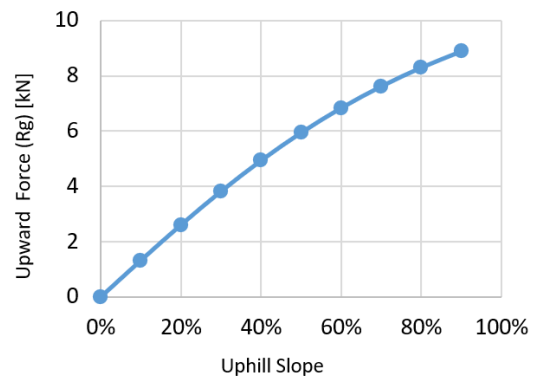

Figure 8. Climbing resistance on vehicles

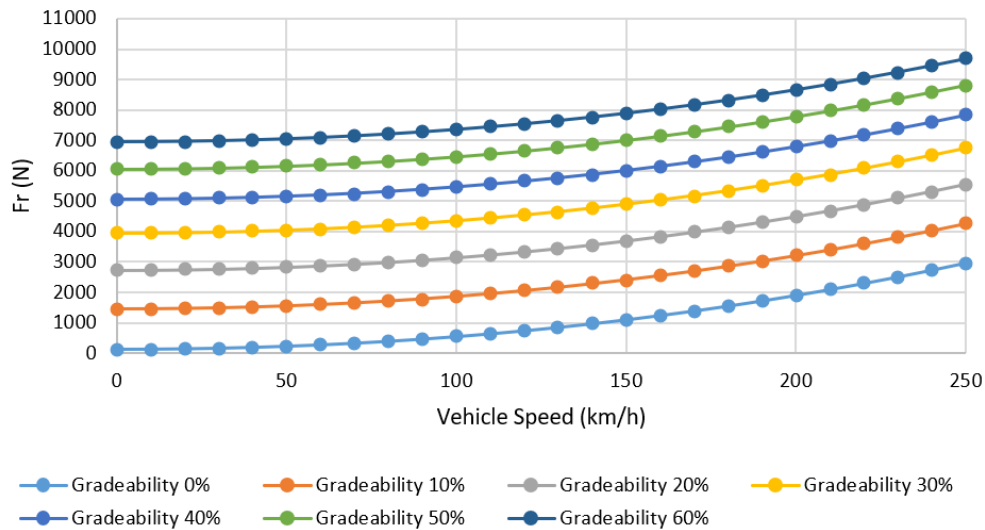

Figure 9. Total Drag Force on vehicles

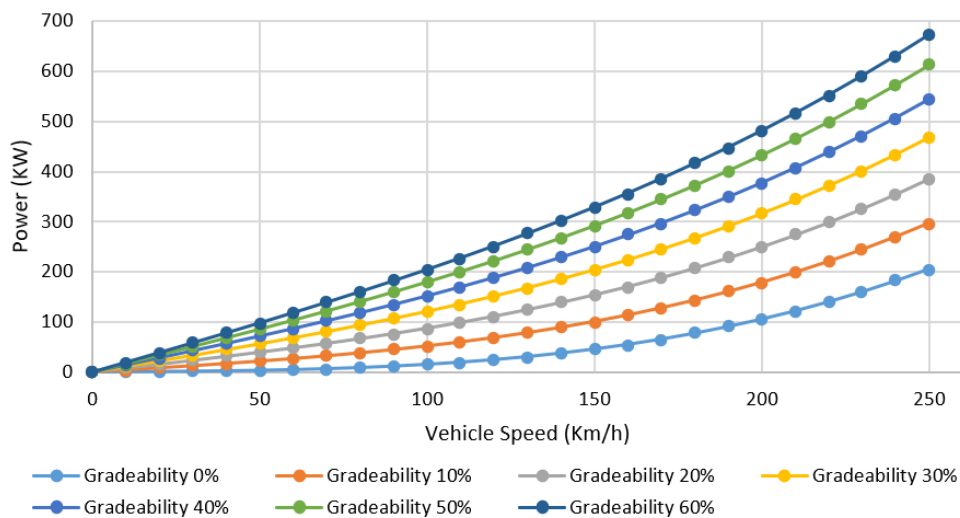

Figure 10. Required Power

The value of the climbing resistance on each gradient is constant. After getting the climbing resistance, the value of the climbing resistance is summed with the wind drag and the rolling resistance to become the total drag force. Figure 9 shows the total drag (F_r) when the vehicle is driving on an upward slope for each gradeability. It can be seen from the graph below that the greater slope, the greater the drag force that occurs. Likewise, if the vehicle passes through the horizontal road, it will experience the least drag force.

After that, to find out the power needed by the vehicle against drag force is the multiplication of the thrust and the speed of the vehicle. The thrust used is the highest value of thrust against the total drag on a 30° slope. The results of the calculation were the motor power requirements to drive a vehicle. This was used as the basis for

determining the specifications of the electric motor. The calculation is shown in Figure 10.

Based on the graph in Figure 10. It can be explained that with 47 kW of power, the vehicle can go on a 300 slope at 20 km/h speed. With 47 kW of power, the vehicle can reach speeds of more than 150 km/h on horizontal roads.

After knowing the drag force and the power requirements for the vehicle, the authors chose the appropriate electric motor. Based on several types of motors available, the authors used the HMP-20000 (50 kW peak power) motor as the motor-1. And HMP-5000 (10 kW peak) motor as motor-2, because motor-2 is used as an auxiliary motor to increase the acceleration of motor-2 and requires a higher rotation speed than motor-1.

The transmission ratio calculation in the vehicle is

to determine the value of the first and final teeth according to the vehicle needed. The first gear is based on the largest thrust against the total drag when climbing, and the largest torque from the electric motor is calculated using Equation 6. With the torque of the electric motor 145 Nm at maximum efficiency, the results can be seen as follows.

$$i_1 = \frac{(W \sin\theta_{max} + f_r \cdot W + R_a) \cdot r}{T_m \cdot I_d \cdot \eta_t} = 6.02$$

Furthermore, the authors calculate the transmission ratio for the final speed, which is 100 km/h. The final transmission ratio is the transmission rate used by the vehicle to produce the desired maximum speed. The final gear is determined using Equation 7, with an electric motor constant torque of 44 Nm. the author has calculated, and the results are as follows.

$$i_m = \frac{(f_r \cdot W + \frac{1}{2} \cdot \rho_{air} \cdot C_d \cdot A_f \cdot V_a) \cdot r}{T_m \cdot I_d \cdot \eta_t} = 1.15$$

While the number of transmission gear levels is adjusted to the vehicle's needs, Table 2 shows the calculation result of the transmission ratio from 3 stages to 6 stage

Table 2. Gear Ratio

3 Stage	4 Stage	5 Stage	6 Stage
i1 = 6.02	i1 = 6.02	i1 = 6.02	i1 = 6.02
i2 = 2.63	i2 = 3.47	i2 = 3.98	i2 = 4.32
i3 = 1.15	i3 = 2.00	i3 = 2.63	i3 = 3.10
	i4 = 1.15	i4 = 1.74	i4 = 2.23
		i5 = 1.15	i5 = 1.60
			i6 = 1.15

transmission. Using Equation 9. This calculation is used to determine the traction characteristics at each transmission ratio level.

Planetary Gear Ratio is designed based on the first and final gear ratios, with the following aspects. The ratio used is 1: 6—the type of transmission (Reduction or Variable Ratio). Maximum vehicle speed and maximum traction requirement. The largest diameter limit allowed on the ring gear is 120 mm, while the ring gear diameter used is 95 mm. The PGS configuration can be seen in Figure 2. Input-2 has a fixed ratio gear (i) to increase the required torque when operating. The fixed-ratio gear will be in contact with the outer gear of the ring gear. So it is determined that the outer gear of the ring gear is 114, and the fixed-gear remains 38, so it has a reduction ratio of 3 times. According to calculations using Equation 14 to Equation 16, the results are shown in Table 3.

After determining the transmission ratio, Traction characteristic analysis was carried out to determine the differences in the various levels of the ratio to the force of the vehicle. Traction characteristics graphs at each speed stage due to the transmission ratio redesign are shown in Figure 11 to Figure 15. From all the redesigned graphs, it can be seen that the traction distribution is more evenly distributed as the number of speed levels increases.

Table 3. PGS Teeth

Sun Gear	Ring Gear	Planet Gear
19	95	38

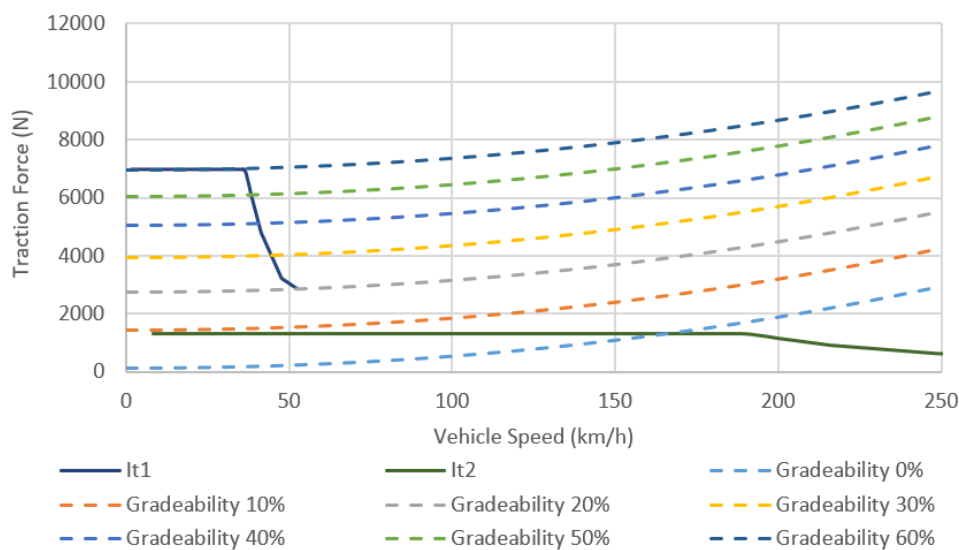

Figure 11. Traction Characteristics 2 Stage of Speed

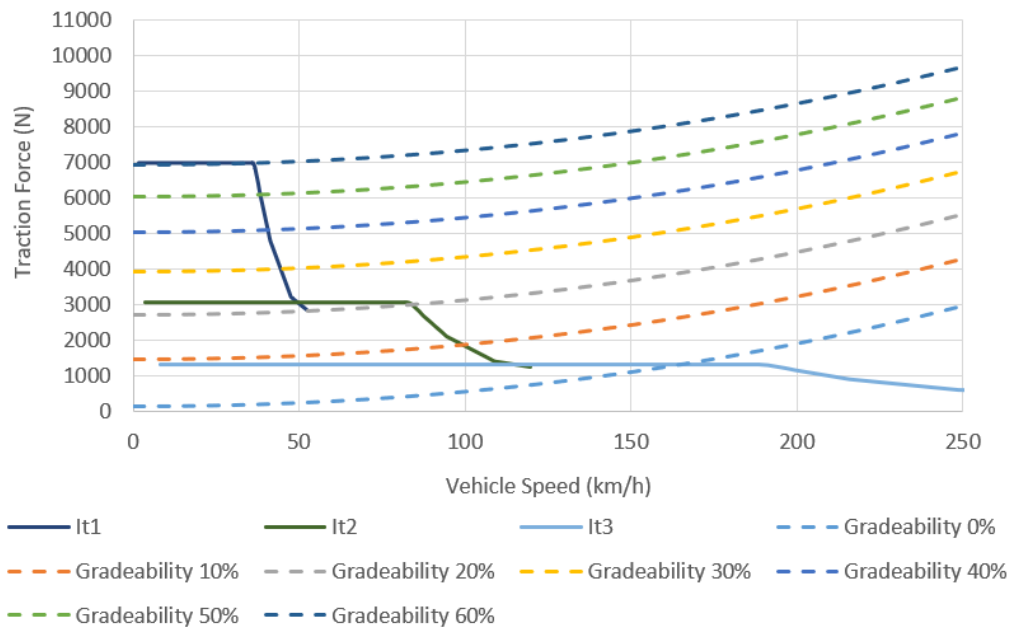

Figure 12. Traction Characteristics 3 Stage of Speed

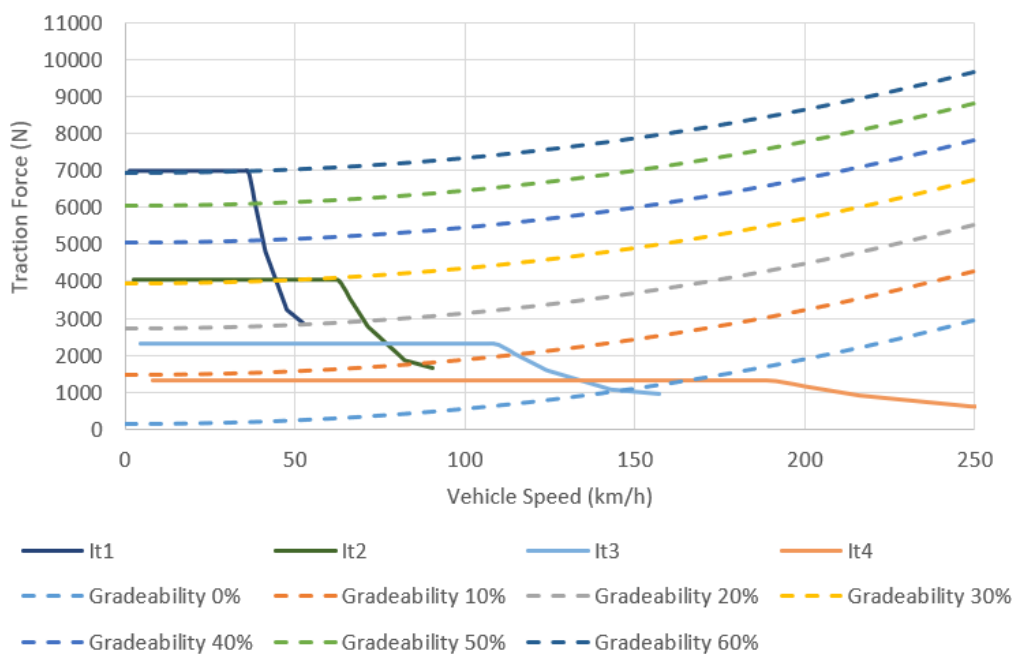

Figure 13. Traction Characteristics 4 Stage of Speed

The maximum traction that can be achieved is 7.01 kN. The traction loss (gap) when changing gears decreases as the transmission level increases. In addition, the top speed of the vehicle of 273 km/h is achieved at the 6th gear level. Both in standard conditions and the redesign results, the car can go through an inclined slope of $\geq 30\%$.

The ECVT mode uses motor-1 and motor-2 to increase the acceleration required by the vehicle. The ECVT mode has less traction than the single motor model; this is due to the counter-torque given by the motor-2 through the ring gear to motor-1 in the sun gear, which has the effect of increasing speed but reducing torque.

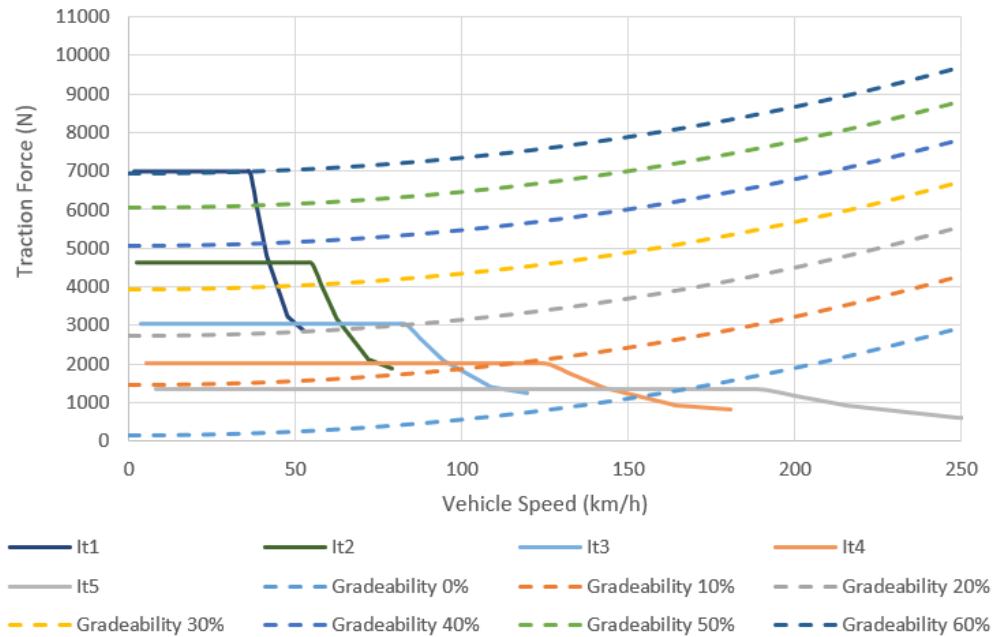

Figure 14. Traction Characteristics 5 Stage of Speed

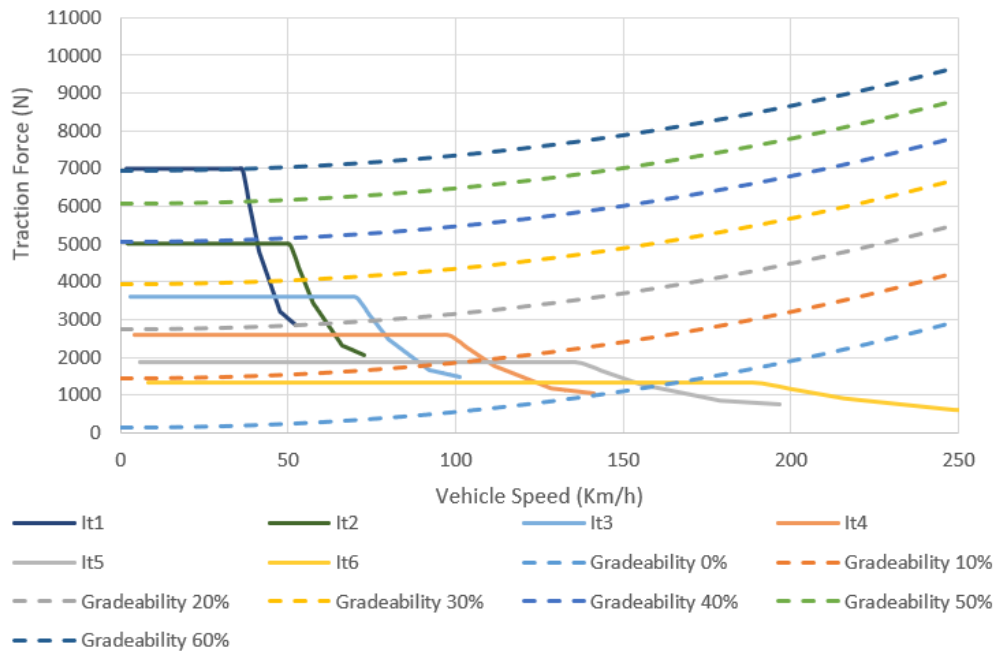

Figure 15. Traction Characteristics 6 Stage of Speed

The next step is design configuration. This configuration is used to validate the design before making a prototype. In this case, the Planetary Gear Set that has been designed will be simulated using the *Matlab Simulink* software and CAD software to get a good and correct prototype. In the simulation, the *Matlab Simulink* software and CAD software basically have similarities in terms of ex-

periments because the researchers used the Sun Gear and Ring Gear input to get the output value. Before performing the simulation using *Matlab*, the design framework is created as the basic simulation. *Simmechanics* in *Matlab* requires a detailed 3D design to get validated results.

The results of CAD simulation can be seen in Figure 16, and the *Matlab Simulink* simulation result can be seen

in Table 4. From Figure 16, the Input Ring 1 is in the opposite direction with Sun Input so that the Carrier Output is obtained. The rotational direction of the input, which is unidirectional, will significantly increase speed. In contrast, the direction of rotation of the input in the opposite direction will reduce the speed and cause a difference in the direction of input and output rotation. So it can be concluded that the use of PGS as a determinant of the speed ratio can be achieved by determining the direction of the input rotation that adapts to the vehicle's need. So that the use of two inputs can increase the reduction ratio in the opposite rotation and increase the acceleration with the same rotation.

In this research, a complete design of ECVT transmission will be produced, supported by detailed prototype images to support the testing process. This transmission is designed in such a way as to make it easier to modify and replace conventional transmissions that already exist in today's vehicles. The results of prototyping can be seen

in Figure 17.

Table 4. Matlab Simulation

Input Sun (rpm)	Input Motor Ring (rpm)	Input Ring (rpm)	Output PGS (rpm)
2000	0	0.0	333.3
2000	1000	333.3	611.1
2000	2000	666.7	888.9
2000	3000	1000.0	1166.7
2000	4000	1333.3	1444.4
2000	5000	1666.7	1722.2
2000	6000	2000.0	2000.0
2000	7000	2333.3	2277.8
2000	8000	2666.7	2555.6
2000	9000	3000.0	2833.3
2000	10000	3333.3	3111.1

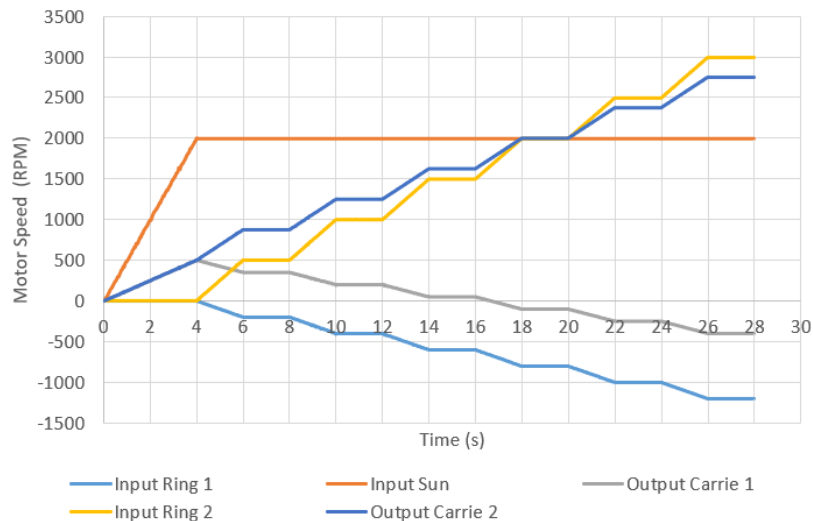

Figure 16. CAD Simulation Result

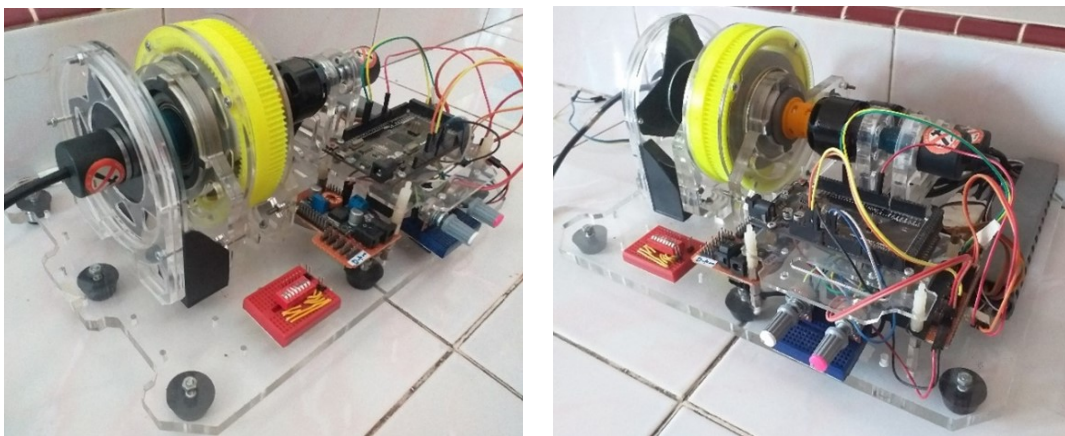

Figure 17. Prototype result

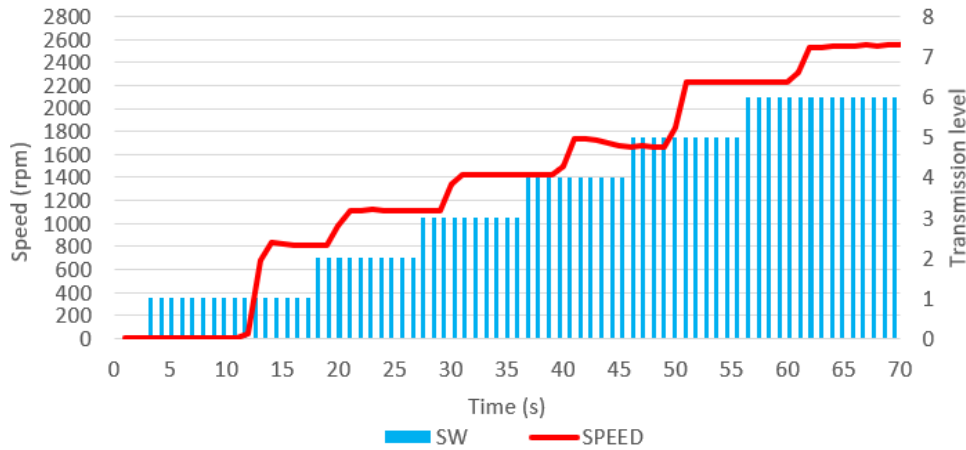

Figure 18. Transmission level – motor speed

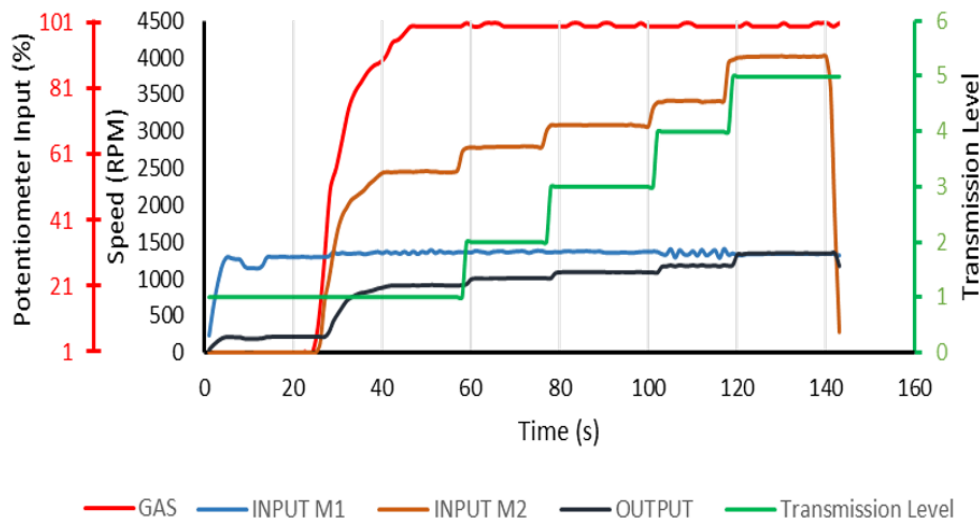

Figure 19. Five speed ECVT mode

The first test on the prototype is to run a motor to find out the rotary encoder sensor readings at the input so that the sensor results are the same as the actual results of the tachometer reading. The second experiment is the application of 5-speed ECVT mode analysis to the prototype. In the first experiment, the result is shown in Figure 18 below. It is known that with every increase in the switch level, the motor speed will increase. The result of second experiment is shown in Figure 19.

The second test was carried out using a potentiometer as input and then determines the input conditions at the maximum level. When the transmission level changes, the maximum speed at the transmission level is obtained. In Figure 19, the red line represents the input given. The initial condition in this test is when the first level transmission is activated, motor-1 will rotate at a constant condition. At 1200 rpm, a light blue line indicates the motor-1

rotation speed condition (INPUT M1). While motor-2 is active when input is given, motor-2 is a determinant of the speed ratio; the selected transmission level greatly influences the speed of motor-2. In the graph above, the speed of motor-2 is known from the brown line (INPUT M2).

The output in this experiment shows that more transmission levels are selected. A yellow line indicates the transmission level, and a black line indicates the output. In the prototype that was made, adding a gear with a ratio of 3:1 at the input motor-2 connected to the Ring gear made the speed of motor-2 very high.

The prototype test results show that PGS in the ECVT mode can determine the vehicle speed ratio. However, the addition of control is needed to increase the effectiveness of the ECVT mode on electric vehicles so that later it can increase the efficiency of electric vehicles.

6. Conclusions

The research has concluded that the ECVT design model with dual motors and a single PGS can make an alternative to determining the speed ratio in electric vehicles. The Planetary Gear Set can be used to facilitate the electric motor to work in optimal conditions. Moreover, it can even produce various modes of operation that can provide additional capabilities for an electric vehicle transmission. The use of ECVT mode in electric vehicles can increase the efficiency of vehicle transmission because the choice of transmission ratio is infinite. Increasing transmission efficiency can increase the efficiency of electric vehicles. However, to obtain maximum efficiency, a good control strategy is needed, and the control strategy will be discussed in further research.

References

- [1] A. Moawad, G. Singh, S. Hagspiel, M. Fellah, and A. Rousseau, "Impact of real world drive cycles on phev fuel efficiency and cost for different powertrain and battery characteristics," *World Electric Vehicle Journal*, vol. 3, no. 1, pp. 186–195, 2009.
- [2] P. N. Auliya and I. N. Sutantra, "Analysis of Power System and Drivetrain Component Design for Toyota Calya Electric Car," *JMES The International Journal of Mechanical Engineering and Sciences*, vol. 4, no. 2, pp. 1–11, 2020.
- [3] F. R. Kalhammer, B. M. Kopf, D. H. Swan, V. P. Roan, and M. P. Walsh, "Status and prospects for zero emissions vehicle technology," *Report of the ARB Independent Expert Panel*, vol. 1, no. 1, pp. 12–36, 2007.
- [4] A. Watts, A. Vallance, A. Whitehead, C. Hilton, and A. Fraser, "The technology and economics of in-wheel motors (2010-01-2307)," *SAE Internat Journ of Passenger Cars-Electronic Electrical Systems*, vol. 3, no. 2, p. 37, 2010.
- [5] M. A. Miller, A. G. Holmes, B. M. Conlon, and P. J. Savagian, "The gm "voltec" 4et50 multi-mode electric transaxle," *SAE International Journal of Engines*, vol. 4, no. 1, pp. 1102–1114, 2011.
- [6] C. Mi and M. A. Masrur, *Hybrid electric vehicles: principles and applications with practical perspectives*. John Wiley & Sons, 2017.
- [7] X. Zhou, P. Walker, N. Zhang, and B. Zhu, "Performance improvement of a two speed ev through combined gear ratio and shift schedule optimization," tech. rep., SAE Technical Paper, 2013.
- [8] F. Yang, L. Du, C. Yao, J. Du, and P. Yu, "The study of operating efficiency enhancement of traction motor with the application of a two-speed transmission in an electric bus," tech. rep., SAE Technical Paper, 2014.
- [9] J. Kim, "Design of a compact 18-speed epicyclic transmission for a personal mobility vehicle," *International Journal of Automotive Technology*, vol. 17, pp. 977–982, Dec 2016.
- [10] D. Tesar, "Multi-speed hub drive wheels," Sept. 2014. US Patent.
- [11] B. Gao, Y. Xiang, H. Chen, Q. Liang, and L. Guo, "Optimal Trajectory Planning of Motor Torque and Clutch Slip Speed for Gear Shift of a Two-Speed Electric Vehicle," *Journal of Dynamic Systems, Measurement, and Control*, vol. 137, 06 2015. 061016.
- [12] P. Walker, B. Zhu, and N. Zhang, "Powertrain dynamics and control of a two speed dual clutch transmission for electric vehicles," *Mechanical Systems and Signal Processing*, vol. 85, pp. 1–15, 2017.
- [13] X. Chen, P. Hang, W. Wang, and Y. Li, "Design and analysis of a novel wheel type continuously variable transmission," *Mechanism and Machine Theory*, vol. 107, pp. 13–26, 2017.
- [14] M. Jamil, *Desain Dan Karakteristik Transmisi Hibrid Elektro Mekanik Untuk Kendaraan Bertenaga Hibrid Pada Moda Ecvt Dan Moda Operasi Lainnya*. PhD thesis, Institut Teknologi Sepuluh Nopember, 2017.
- [15] M. Chris, M. A. Masrur, and D. W. Gao, "Hybrid electric vehicles: principles and applications with practical perspectives," *Masrur, David WenzhongGap*, 2011.
- [16] F. Yang, J. Feng, and F. Du, "Design and power flow analysis for multi-speed automatic transmission with hybrid gear trains," *International Journal of Automotive Technology*, vol. 17, pp. 629–637, Aug 2016.